

HP 83236A PCS Interface
CDMA/PCS Base Station Test Software, *User's Guide*

Software Version A.00.00

HP Part No. 83236-90020
Printed in U. S. A.
August 1996

Revision A

Copyright © Hewlett-Packard Company 1996

**RESTRICTED
RIGHTS LEGEND**

Use, duplication or disclosure by the U. S. Government is subject to restrictions as set forth in subparagraph (c) (1) (ii) of the Rights in Technical Data and Computer Software Clause in DFARS 252.227-7013.

Hewlett-Packard Company
3000 Hanover Street
Palo Alto, CA 94304
U.S.A.

Rights for non-DOD U. S. Government Departments and Agencies are as set forth in FAR 52.227-19 (c) (1, 2).

In this Book

This book is a supplement to the *HP 83236A PCS Interface Operating Guide*. The *Operating Guide* provides information on System installation, programming, and technical specifications. This book focuses specifically on the use of the PCS Interface in testing CDMA/PCS base station equipment.

Chapter 1, Getting Started

This chapter provides the steps for loading and running the CDMA/PCS base station test software. Start here.

Chapter 2, Making Measurements

After you have the software loaded and running, use this chapter to see each measurement's steps for CDMA transmitter and receiver testing.

Chapter 3, Operating Overview

General information on software use is found in this chapter.

Chapter 4, Troubleshooting

This chapter offers reference material to be used if you encounter errors while using the software.

Conventions Used in this Guide

The following *terms* are used throughout this guide:

- Test Set - the HP 8921A Cell Site Test Set.
- Cellular Adapter - the HP 83203B or 83205A CDMA Cellular Adapter.
- PCS Interface - the HP 83236A; used to translate signals into the range of the Test Set.
- Software - the CDMA/PCS Base Station Test Software, described in this book.
- System - the combination of a Test Set, a Cellular Adapter, and a PCS Interface.

The Test Set's keys, softkeys, and selection choices in menu screens are shown as follows:

- A key on the Test Set's front panel: **TESTS**
- A User Key: **Prev Menu** (k5)
- A selection choice or setting on the CRT display: **Equipment Type**

Contents

1 Getting Started

Introduction 12

Who should use the CDMA/PCS BS Test Software? 12

Product Description 12

Software Operation in Brief 12

Required Equipment 13

Step 1: Make Connections 14

Step 2: Load and Run the CDMA/PCS BS Test Software 15

Navigation of the CDMA/PCS BS Test Software 17

Step 3: Configure the Software 18

Step 4: Perform CDMA Tests 20

If You Had Problems 20

2 Making Measurements

Overview 23

Transmitter Measurements 23

Receiver Measurements 23

Average Power 24

Overview 24

Requirements 24

Steps 25

Notes 25

Modulation Quality (Rho) 26

Overview 26

Requirements 26

Steps 27

Notes 27

Code Domain Power 28

Overview 28

Requirements 28

Steps 29

Notes 29

Code Domain Timing 30

Overview 30

Requirements 30

Steps 31

Notes 31

Code Domain Phase 32

Overview 32

Requirements 32

Steps 33

Notes 33

Transmit Spectrum 34

Overview 34

Contents

Requirements 34
Steps: Go to Spectrum Analyzer @ Present Chan 35
Steps: Go to Spectrum Analyzer & Enter Freq 36
Notes 37

Receiver Sensitivity 38

Overview 38
Requirements 38
Steps 39
Notes 39

Receiver Performance in Additive Noise 40

Overview 40
Requirements 40
Steps 41
Notes 41

3 Operating Overview

Overview 44

Configuration Information 44

Reference Information 44

Compensating for TX and RX Measurement Path Loss 45

Requirements 45

Steps 45

Notes 45

Saving Configuration Information to a Memory Card 46

Requirements 46

Steps 46

Notes 47

Loading Configuration Information from a Memory Card 48

Requirements 48

Steps 48

Notes 48

Using Autostart 49

Turning On the Autostart Feature 49

Turning Off the Autostart Feature 49

Notes 49

Viewing Instrument Connections 50

Steps 50

Notes 50

Setting the System “Beep” 51

Steps 51

Notes 51

An Alternative System-to-Base-Station Timebase Configuration 52

Steps 52

Notes 53

Contents

4 Troubleshooting

Overview 56

Errors When Loading and Running the Software 57

Memory Overflow Errors 57

System Configuration Errors at Runtime 58

Other System Configuration Errors 59

Configuration Information is Not Updated as Saved 59

Menu Screens in this Book do not Match the Screens that You See 60

Errors While Attempting Measurements 61

CDMA Measurement not Correlating 61

Frame Error Rate (Receiver Measurements) 62

Suspect Measurement Results 64

Overview 64

Average Power 64

Rho Measurements 65

Code Domain Measurements 65

Receiver Tests 66

Glossary 67

Index 73

Contents

Getting Started

Follow the steps in this chapter to load and run the CDMA/PCS BS Test Software, to connect the test equipment, and to make initial settings to configure your System.

Introduction

Who should use the CDMA/PCS BS Test Software? If you are installing, commissioning, or maintaining Personal Communication Services (PCS) sites using the Code Division Multiple Access (CDMA) standard, this software will assist you in performing key tests of transmitter and receiver performance.

Product Description The HP 83236A CDMA/PCS BS Test software is an Instrument BASIC (IBASIC) application used to set up the PCS Interface for transmitter and receiver measurements on CDMA base station equipment. The software runs on the Test Set's internal IBASIC controller to allow you to manually control the PCS Interface (which has no front-panel controls).

The CDMA/PCS BS Test Software is designed to run on the HP 8921A Cell Site Test Set using the HP 83203B or HP 83205A Cellular Adapters (an equivalent configuration is the HP 8921A Option 600,603). This combination of test equipment plus the Software is hereafter referred to as the "System".

Software Operation in Brief This software does not perform automated measurements of a CDMA base station; it controls the System then allows you to make these measurements manually, using the CDMA test screens. The basic steps are:

- Set up the base station and test equipment.
- Load and run the software.
- Enter information about your base station.
- The software configures the System to test.
- Exit the software and go to the CDMA screens.
- Make your CDMA measurement(s).

The first four steps are detailed in this chapter. The remaining steps are presented in "Making Measurements" in chapter 2.

Required Equipment

You must supply:

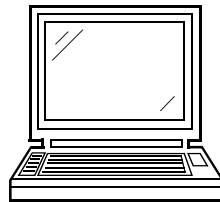

Means to control base station and read FER.

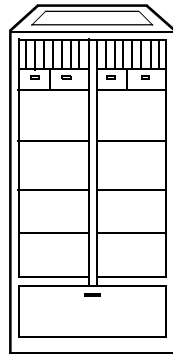

CDMA PCS Base Station.

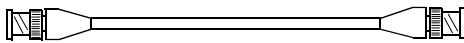

Cables to connect the base station to the System.
(See table below.)

Supplied with the System:

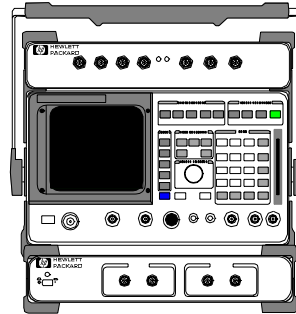

HP 8921A Opt. 600,603 or an HP 8921A with an HP 83203B or 83205A Cellular Adapter.

HP 83236A PCS Interface

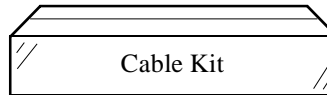

HP 83236A Cable Kit (Supplied with the HP 83236A)

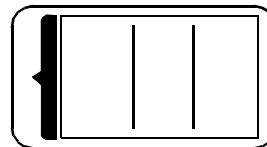

CDMA PCS Base Station Test Software (Supplied with the HP 83236A)

Label:
HP 83236A System Connectivity and Manual Control Software

Item	Connector at System end	Connections
1	N (m)	Connects base station's transmitter test port to PCS Interface RF IN/OUT port.
2	N (m)	Connects PCS interface RF IN/OUT port to base station's receiver test port.
3	BNC (m)	Connects Even-Second clock from BS to EVEN SEC/SYNC port on Cellular Adapter.
4	BNC (m)	Connects BS Timebase reference to timebase input on the Cellular Adapter.

Figure 1

Step 1: Make Connections

Make the connections between the elements of the System and the base station as shown in figure 2.

NOTE

This figure does not illustrate all rear-panel connections between the Cellular Adapter and Test Set. Refer to the *Cellular Adapter User's Guide* to verify these connections.

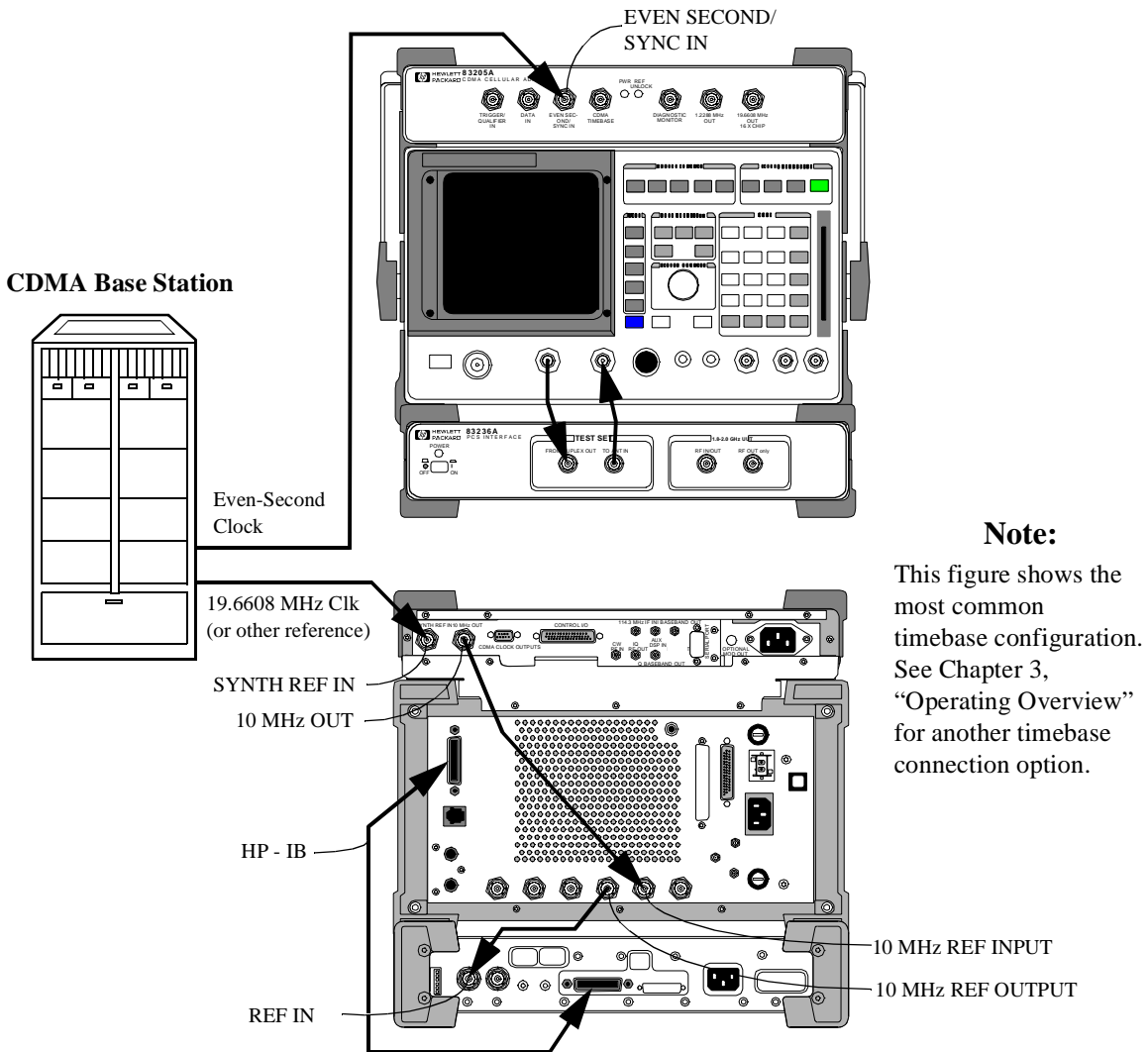

Note:

This figure shows the most common timebase configuration. See Chapter 3, "Operating Overview" for another timebase connection option.

Figure 2

Step 2: Load and Run the CDMA/PCS BS Test Software

The next step is to get the CDMA/PCS BS Test Software loaded into the Test Set and running on the IBASIC controller. Locate the memory card supplied with the PCS Interface and follow the steps outlined in figure 3 and figure 4.

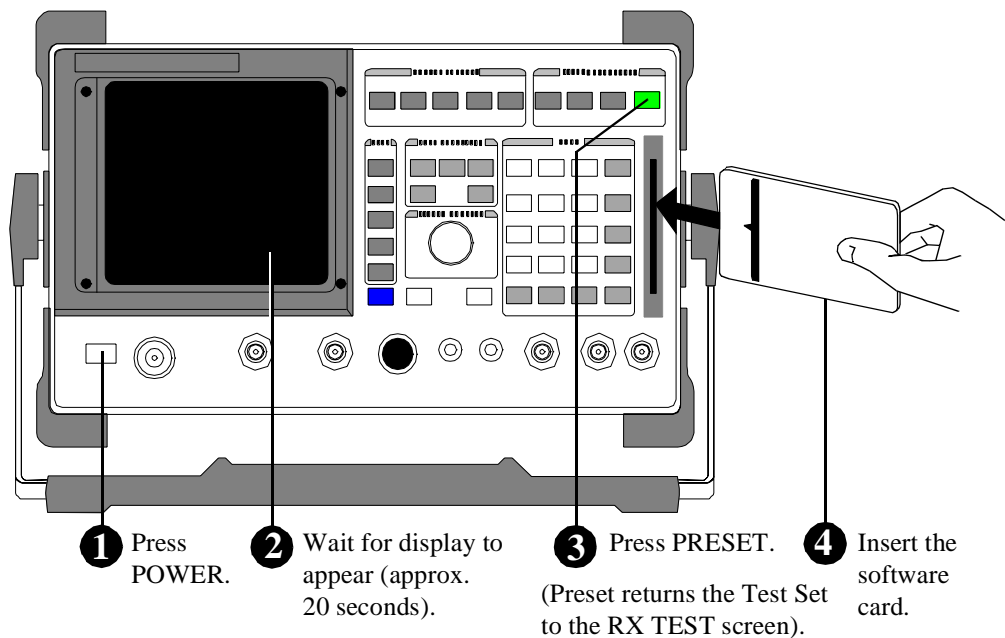

Continued on the following page

Figure 3

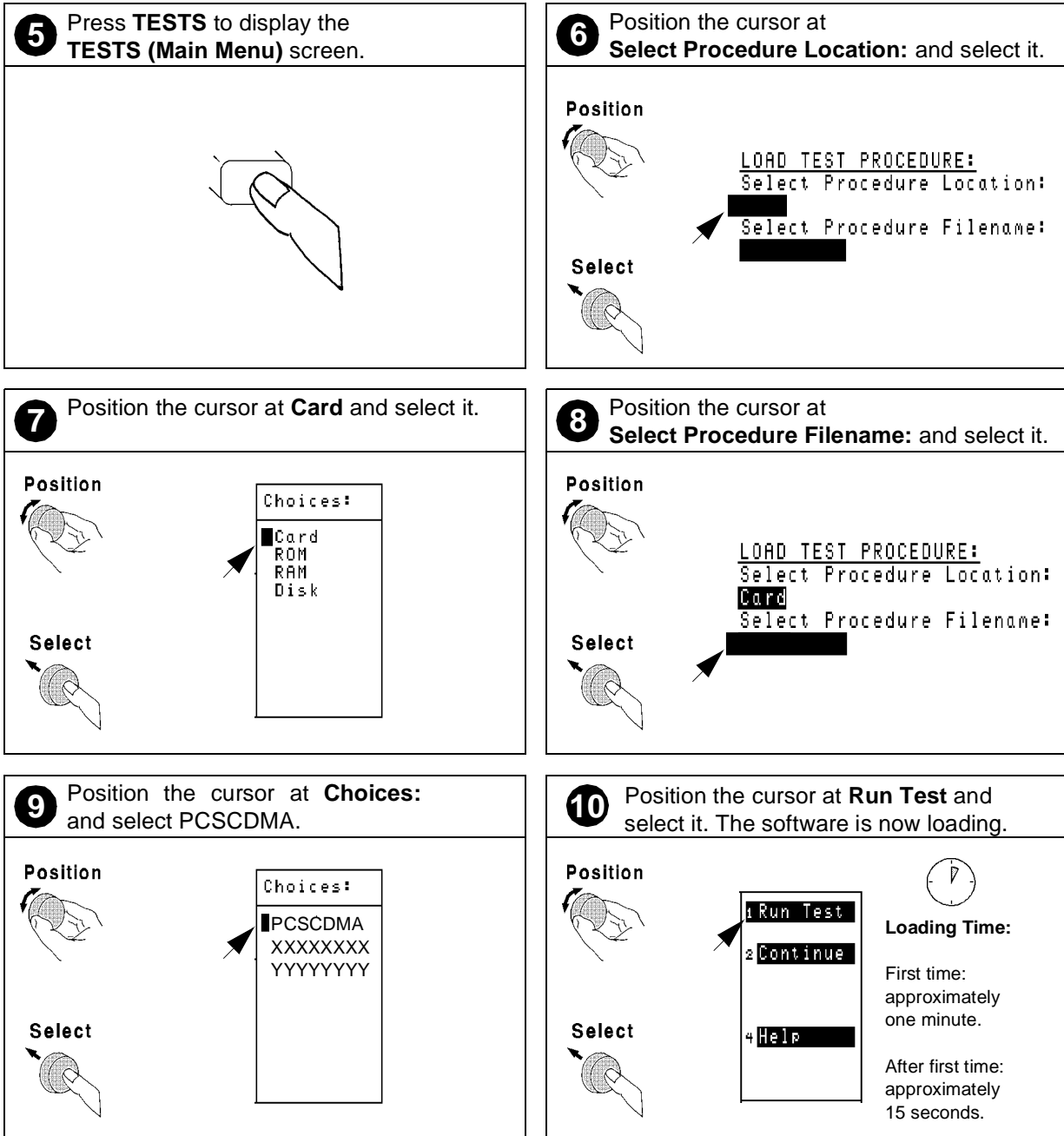

Figure 4

Navigation of the CDMA/PCS BS Test Software

After the software has loaded, you should see the CDMA/PCS BS Test Software main menu screen on the display of the Test Set (see figure 5). Important features of this screen are indicated in the figure with notes on their use.

Main Selections and Cursor Control

Some menu selections open lower-level menus, others allow entry of numeric data. To select a menu item, rotate the knob until the cursor is in front of the line and press the knob.

Entry Fields

Some main menu selections are entry fields. When these are selected, a highlighted area appears and you may key in a value with the DATA keys, or rotate the knob to change the value in the field. When the desired value is set, press the knob or the ENTER key.

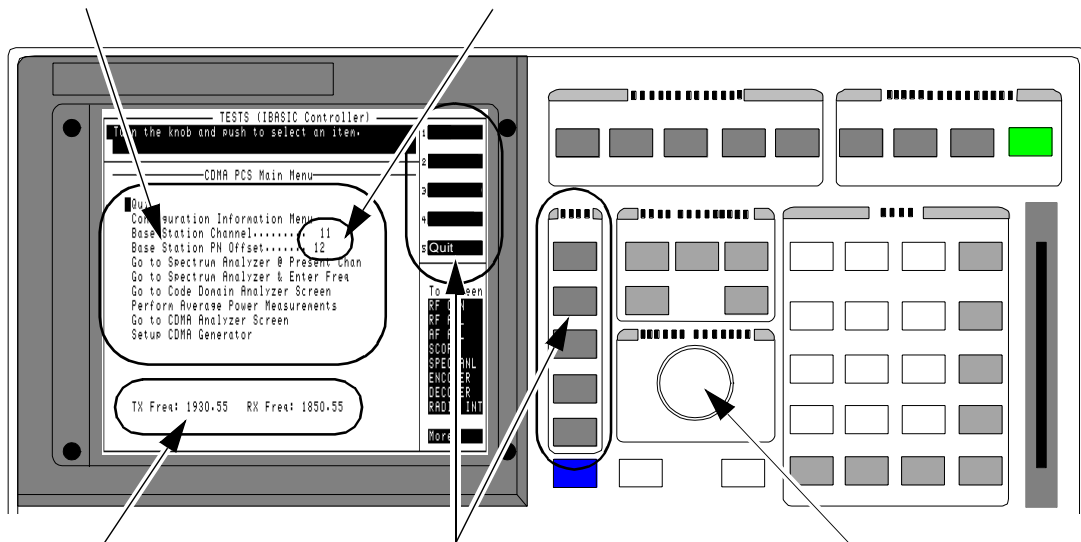

Tuned Frequency

This area displays the frequency settings for the CDMA analyzer and signal generator.

USER Keys and their Fields

The USER Keys (k1 - k5) correspond to fields 1-5 at the top right corner of the test screen. They are used for navigation through menus and for making selections. In most lower-level menus, a "Prev Menu" key is provided to take you up one menu level.

Knob

The knob controls the cursor position on the display and is sometimes used to make numeric entries.

Figure 5 CDMA/PCS BS Test Software main menu features.

Step 3: Configure the Software

The first time you run the Software you must enter information about your setup and the base station being tested. Use these steps:

1 From the CDMA PCS Main Menu, scroll to and select **Configuration Information Menu**.

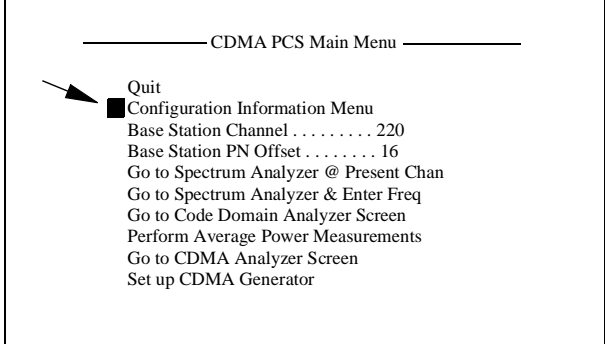

————— CDMA PCS Main Menu —————

- Quit
- Configuration Information Menu
- Base Station Channel 220
- Base Station PN Offset 16
- Go to Spectrum Analyzer @ Present Chan
- Go to Spectrum Analyzer & Enter Freq
- Go to Code Domain Analyzer Screen
- Perform Average Power Measurements
- Go to CDMA Analyzer Screen
- Set up CDMA Generator

2 Scroll to and select **Base Station Reference Freq.**

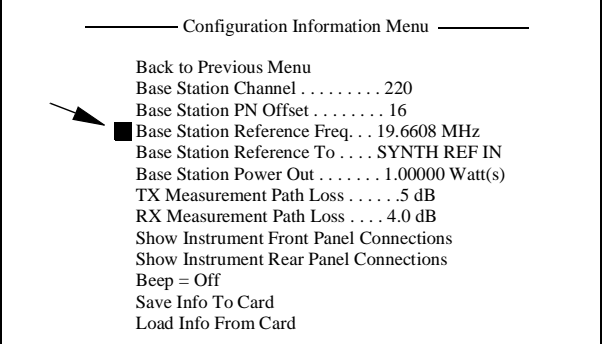

————— Configuration Information Menu —————

- Back to Previous Menu
- Base Station Channel 220
- Base Station PN Offset 16
- Base Station Reference Freq. 19.6608 MHz
- Base Station Reference To SYNTH REF IN
- Base Station Power Out 1.00000 Watt(s)
- TX Measurement Path Loss 5 dB
- RX Measurement Path Loss 4.0 dB
- Show Instrument Front Panel Connections
- Show Instrument Rear Panel Connections
- Beep = Off
- Save Info To Card
- Load Info From Card

3 Scroll to and select the clock frequency of the timebase signal at the SYNTH REF IN port.

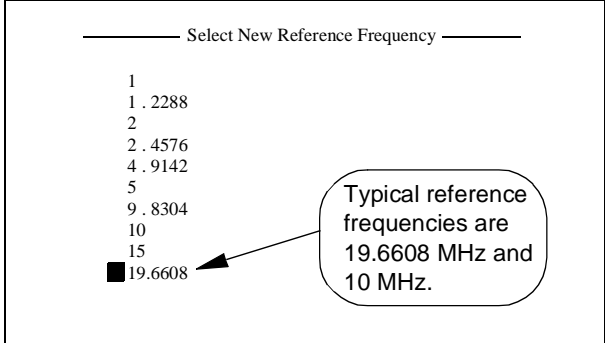

————— Select New Reference Frequency —————

- 1
- 1 . 2288
- 2
- 2 . 4576
- 4 . 9142
- 5
- 9 . 8304
- 10
- 15
- 19.6608

Typical reference frequencies are 19.6608 MHz and 10 MHz.

4 Scroll to and select **Base Station Power Out** and enter the level of your transmitted signal.

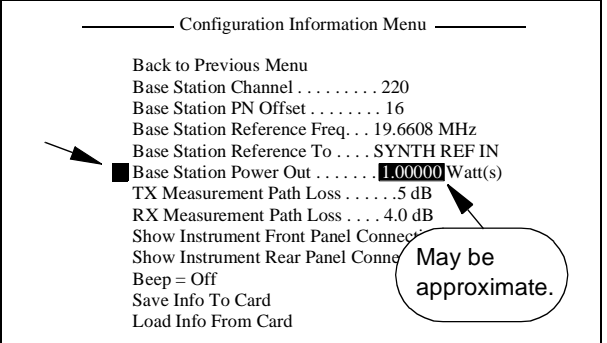

————— Configuration Information Menu —————

- Back to Previous Menu
- Base Station Channel 220
- Base Station PN Offset 16
- Base Station Reference Freq. 19.6608 MHz
- Base Station Reference To SYNTH REF IN
- Base Station Power Out 1.00000 Watt(s)
- TX Measurement Path Loss 5 dB
- RX Measurement Path Loss 4.0 dB
- Show Instrument Front Panel Connections
- Show Instrument Rear Panel Connections
- Beep = Off
- Save Info To Card
- Load Info From Card

May be approximate.

Continued on the following page

5 Scroll to and select **TX Measurement Path Loss**. Enter the loss (through cables, couplers and attenuators) between your base station's transmitter test port and the RF IN/OUT port of the PCS Interface.

————— Configuration Information Menu —————

```

Back to Previous Menu
Base Station Channel . . . . . 220
Base Station PN Offset . . . . . 16
Base Station Reference Freq. . . 19.6608 MHz
Base Station Reference To . . . . SYNTH REF IN
Base Station Power Out . . . . . 1.00000 Watt(s)
■ TX Measurement Path Loss . . . . 0.5 dB ←
RX Measurement Path Loss . . . . 4.0 dB
Show Instrument Front Panel Connections
Show Instrument Rear Panel Connections
Beep = Off
Save Info To Card
Load Info From Card
  
```

Enter the value into the highlighted field. The software will compensate for cable loss, improving measurement accuracy.

6 Scroll to and select **RX Measurement Path Loss**. Enter the loss of the RF cable (include loss through splitters, and so forth) between your base station's receiver test port and the RF IN/OUT port of the PCS Interface.

————— Configuration Information Menu —————

```

Back to Previous Menu
Base Station Channel . . . . . 220
Base Station PN Offset . . . . . 16
Base Station Reference Freq. . . 19.6608 MHz
Base Station Reference To . . . . SYNTH REF IN
Base Station Power Out . . . . . 1.00000 Watt(s)
TX Measurement Path Loss . . . . 0.5 dB
■ RX Measurement Path Loss . . . . 4.0 dB ←
Show Instrument Front Panel Connections
Show Instrument Rear Panel Connections
Beep = Off
Save Info To Card
Load Info From Card
  
```

Enter the value into the highlighted field. The software will compensate for cable loss, improving measurement accuracy.

7 This completes the required entries. You may now save your entries or press the **Prev Menu** (k5) key to return to the main menu. To save entries see, "Saving Configuration Information to a Memory Card" in Chapter 3.

————— Configuration Information Menu —————

```

Back to Previous Menu
Base Station Channel . . . . . 220
Base Station PN Offset . . . . . 16
Base Station Reference Freq. . . 19.6608 MHz
Base Station Reference To . . . . SYNTH REF IN
Base Station Power Out . . . . . 1.00000 Watt(s)
TX Measurement Path Loss . . . . 0.5 dB
RX Measurement Path Loss . . . . 4.0 dB
Show Instrument Front Panel Connections
Show Instrument Rear Panel Connections
Beep = Off
Save Info To Card
Load Info From Card
  
```

USER

k1

k2

k3

k4

k5

User keys 1-5 correspond to the fields on the top right corner of the test set screen.

Step 4: Perform CDMA Tests

Now that you have successfully run the software and entered your configuration values, you can go on to making CDMA measurements. Refer to chapter 2, "Making Measurements" to see detailed steps for performing CDMA measurements.

If You Had Problems

If you were unable to load and run the software or make the required entries, refer to chapter 4, "Troubleshooting" for help.

Making Measurements

This chapter contains descriptions of the most common receiver and transmitter tests performed on CDMA base station equipment. For each test, requirements are listed and the steps to perform the measurement are provided.

Overview

This chapter presents measurement tasks most commonly performed when testing CDMA/PCS base station equipment. The measurements are separated by type: transmitter tests, followed by the receiver tests. For descriptions of general software use, refer to the chapter 3, "Operating Overview".

NOTE:

The test procedures outlined in this chapter require that you have already configured the system as outlined in chapter 1, "Getting Started".

Transmitter Measurements

- "Average Power" on page 24
- "Modulation Quality (Rho)" on page 26
- "Code Domain Power" on page 28
- "Code Domain Timing" on page 30
- "Code Domain Phase" on page 32
- "Transmit Spectrum" on page 34

Receiver Measurements

- "Receiver Sensitivity" on page 38
- "Receiver Performance in Additive Noise" on page 40

Average Power

Overview

Average power is a time-averaged broadband measurement of the transmitted signal strength at the RF IN/OUT port on the front panel of the PCS Interface. The average power measurement is “uncorrelated”; it *does not require* the reference signals needed for other tests (Even-Second clock and 19.6608 MHz timebase).

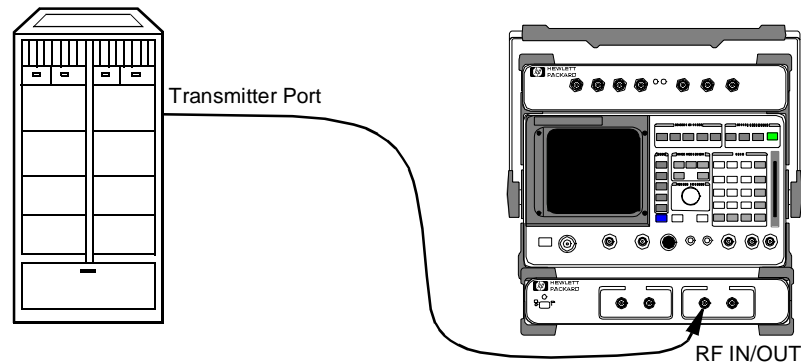

Figure 6

CAUTION:

Before performing any transmitter measurements, make sure that the power level applied to the RF IN/OUT port of the PCS Interface does not exceed the published limit. For CDMA base station signals this is 1 Watt (+30 dBm). You may have to use an external attenuator or directional coupler, depending on the power output for your transmitter. Signal levels greater than the specified maximum can cause damage to the test equipment.

Requirements

- You should know the following about your base station and setup:
 - The base station channel number setting.
 - The approximate output power at the port where the test equipment will be connected.
 - The path loss for the cables and any attenuators, couplers, and so forth.
- You must have a means of controlling the base station to turn on the transmitter, set the channel number, and so forth.

Steps

- 1 Connect the equipment as shown in figure 6.
- 2 In the main menu, enter the **Base Station Channel** number for the transmitter being tested.
- 3 Set up the base station to transmit on the channel number entered in step 2.
- 4 From the main menu, choose **Perform Average Power Measurements**.
- 5 The resulting menu (see figure 7) will display average power (in Watts) applied to the RF IN/OUT port. The average power displayed is corrected for the loss value entered in the **Configuration Information Menu** under **TX Measurement Path Loss**.
- 6 You can change the measurement's units to milliwatts or dBm using USER keys k3 and k4, respectively.
- 7 USER key k1 will re-zero the power meter. It is *not* necessary to remove power from the RF IN/OUT port of the PCS Interface to zero the power meter.
- 8 Press the **Prev Menu** (k5) key to return to the main menu.

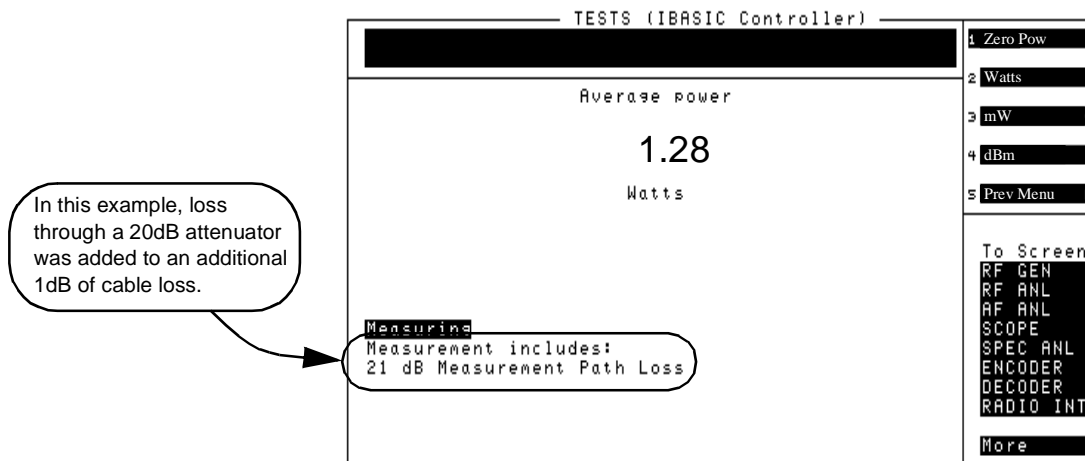

Figure 7

Notes

To minimize measurement errors due to temperature drift, occasional zeroing of the power meter is recommended. An initial zeroing is performed when you enter the **Average Power** measurement screen. It is *not* necessary to remove the signal from the RF IN/OUT port of the PCS Interface for zeroing.

If you want to test average power at another frequency, return to the main menu level and update the **Base Station Channel** entry, then repeat the steps listed above.

Modulation Quality (Rho)

Overview

In this measurement, the modulated signal is compared to an ideal, reference waveform to determine the performance of the transmitter's modulation circuitry. Rho values are in the range of 0 to 1. A value of 1 indicates perfect correlation to the reference (high modulation quality). CDMA base station standards require that transmitters have rho performance of 0.912 or higher.

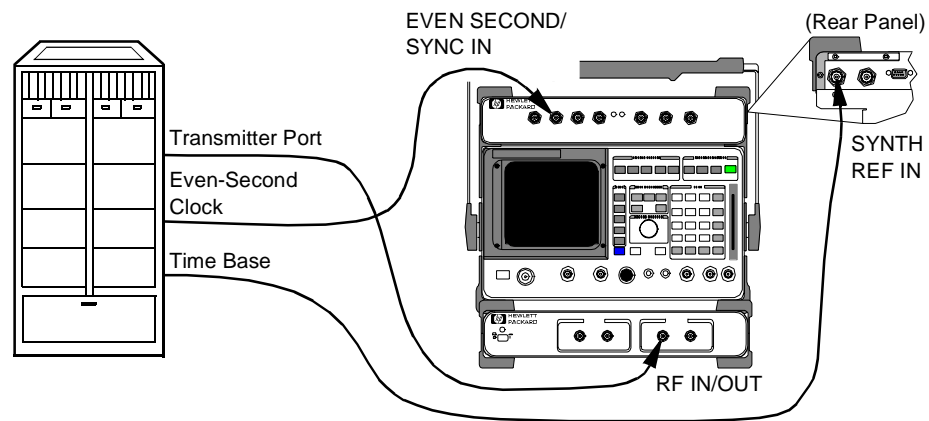

Figure 8

CAUTION:

Before performing any transmitter measurements, make sure that the power level applied to the RF IN/OUT port of the PCS Interface does not exceed the published limit. For CDMA base station signals this is 1 Watt (+30 dBm). You may have to use an external attenuator or directional coupler, depending on the power output for your transmitter. Signal levels greater than the specified maximum can cause damage to the test equipment.

Requirements

- Synchronization is required, so you must have an Even-Second clock signal and a reference timebase (typically 19.6608 MHz) from the base station.
- You must have the ability to transmit the pilot channel only (Walsh 0).
- You must know the following about the base station and setup:
 - The base station channel number setting.
 - The PN Offset for the base-station-under-test.

Steps

- 1 Connect the equipment as shown in figure 8.
- 2 In the main menu, enter the **Base Station Channel** number for the transmitter being tested.
- 3 Also in the main menu, enter the **Base Station PN Offset** for the base-station-under-test.
- 4 Scroll to and select **Go to CDMA Analyzer Screen**.
- 5 If **Rho** does not already show in the upper left measurement field (other measurement options are **Chan Pwr**, **EVM**, and **Avg Pwr**), place the cursor on the field, push the knob, and select **Rho** (see figure 9).
- 6 Set up the base station to transmit on the channel number entered in step 2.
- 7 Verify that the REF UNLOCK light on the front of the Cellular Adapter is *not* lit.
- 8 Read the value under the **Rho** field.
- 9 To return to the main menu press SHIFT, then k1, then ENTER.

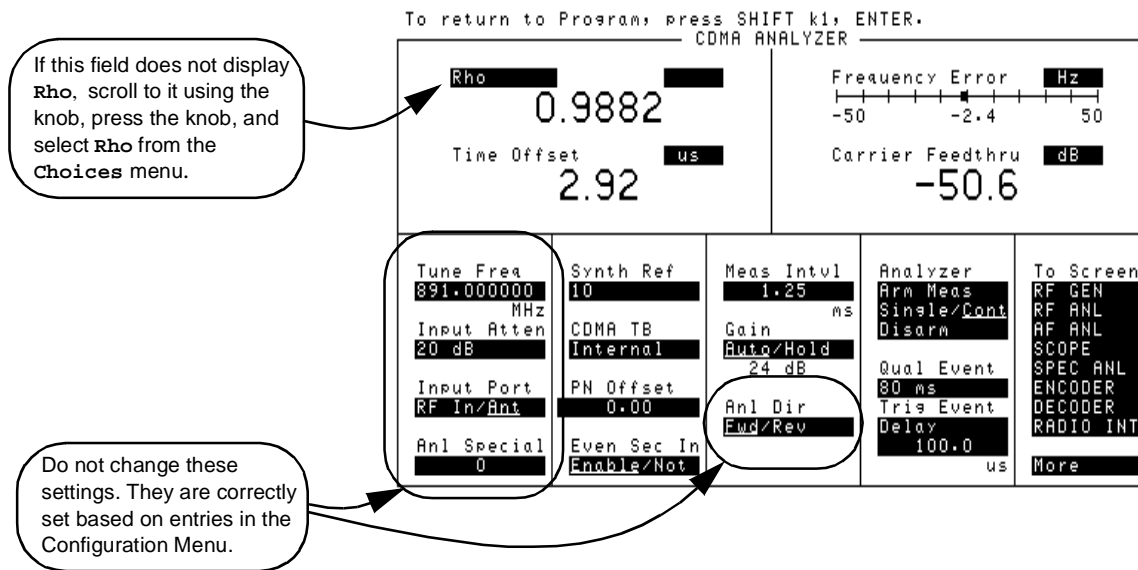

Figure 9

Notes

While using the CDMA ANALYZER Screen, do not make changes to fields that are controlled by the software. These include **Tune Freq**, **Input Port**, and **Anl Dir** (see figure 9). Changes made to these fields in the CDMA ANALYZER Screen may affect operation at a later time.

Code Domain Power

Overview

The Code Domain Power measurement shows the relative power in each of the Walsh channels of a transmitted signal. Signal strength of the Pilot, Paging, Sync, and Traffic channels are displayed (in dB).

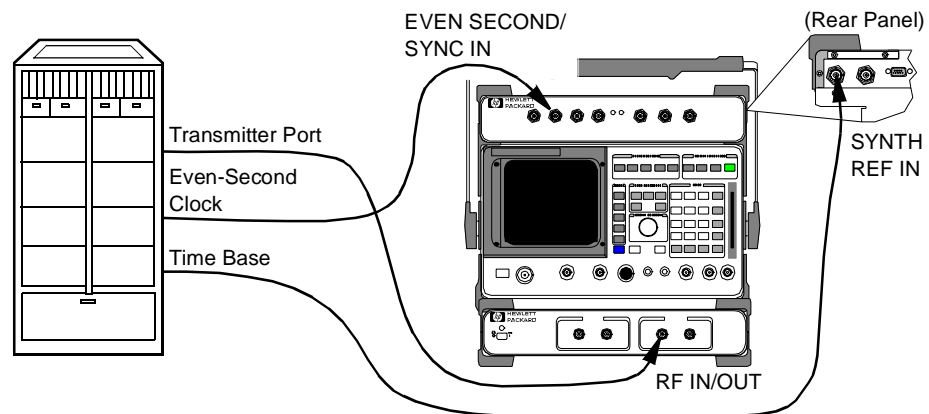

Figure 10

CAUTION:

Before performing any transmitter measurements, make sure that the power level applied to the RF IN/OUT port of the PCS Interface does not exceed the published limit. For CDMA base station signals this is 1 Watt (+30 dBm). You may have to use an external attenuator or directional coupler, depending on the power output for your transmitter. Signal levels greater than the specified maximum can cause damage to the test equipment.

Requirements

- You must have a means of turning on the base station transmitter and enabling various Walsh channels (Pilot, Sync, Traffic, and Paging).
- Synchronization is required, so you must have an Even-Second clock signal and a reference timebase (typically 19.6608 MHz) from the base station.
- You must know the following about the base station and setup:
 - The base station channel number setting.
 - The PN Offset for the base-station-under-test.
 - The approximate power output at the port the test equipment will be connected to.

Steps

- 1 Connect the equipment as shown in figure 10.
- 2 In the main menu, enter the **Base Station Channel** number for the transmitter being tested.
- 3 Also in the main menu, enter the **Base Station PN Offset** for the base-station-under-test.
- 4 Scroll to and select **Go to Code Domain Analyzer Screen**.
- 5 Verify that the **Measurement** field at the bottom of the display is set to **Power**. Scroll down and set it to **Power**, if not.
- 6 If the signal is correlated, you should see a display similar to that of figure 11, showing the pilot channel's level (Walsh 0) and any other Sync, Paging, or Traffic channels that are active.
- 7 To return to the main menu press SHIFT, then k1, then ENTER.

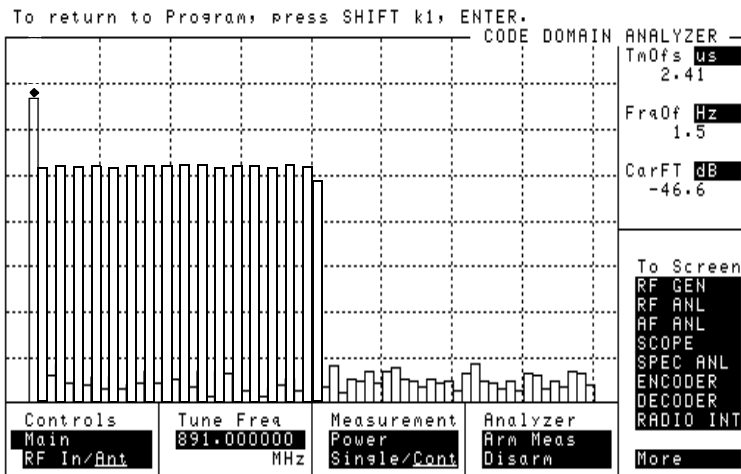

Figure 11

Code domain power display with a number of traffic channels enabled.

Notes

The **Tune Freq** displayed at the bottom of the **CODE DOMAIN ANALYZER** screen does not indicate the true tuned frequency of the System. The tuned frequency is calculated from your entry for **Base Station Channel** and can be viewed at the bottom of the main menu screen. Do not make changes to the **Tune Freq** setting of the **CODE DOMAIN ANALYZER** screen.

If you are planning to test Code Domain Timing or Code Domain Phase, you can use the **Measurement** field to activate them without having to return to the main menu.

Refer to the *HP 83203B, 83205A Cellular Adapter User's Guides* for more details on the use of the Code Domain Power screen.

Code Domain Timing

Overview

Similar to the Code Domain Power test, this measurement shows the timing relationship between the various Walsh channels and the Pilot channel.

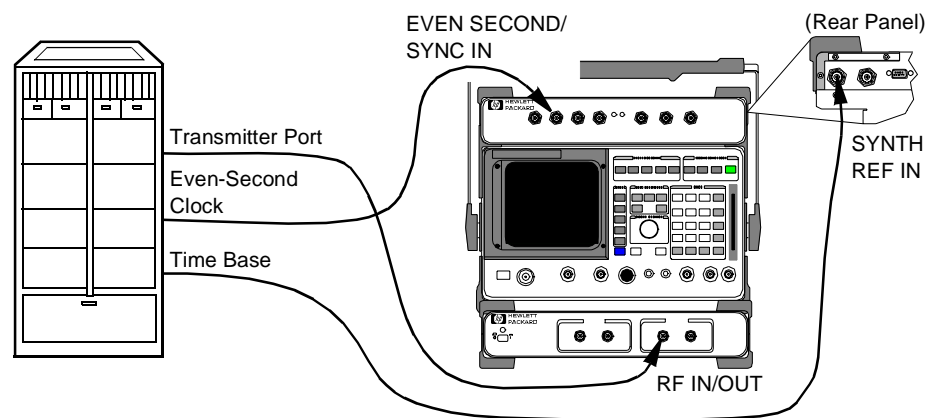

Figure 12

CAUTION:

Before performing any transmitter measurements, make sure that the power level applied to the RF IN/OUT port of the PCS Interface does not exceed the published limit. For CDMA base station signals this is 1 Watt (+30 dBm). You may have to use an external attenuator or directional coupler, depending on the power output for your transmitter. Signal levels greater than the specified maximum can cause damage to the test equipment.

Requirements

- You must have a means of turning on the base station transmitter and enabling various Walsh channels (such as Pilot, Sync, Traffic, and Paging).
- Synchronization is required, so you must have an Even-Second clock signal and a reference timebase (typically 19.6608 MHz) from the base station.
- You must know the following about the base station and setup:
 - The base station channel number setting.
 - The PN Offset for the base-station-under-test.
 - The approximate power output at the port the test equipment will be connected to.

Steps

- 1 Connect the equipment as shown in figure 12.
- 2 In the main menu, enter the **Base Station Channel** number for the transmitter being tested.
- 3 Also in the main menu, enter the **Base Station PN Offset** for the base-station-under-test.
- 4 Scroll to and select **Go to Code Domain Analyzer Screen**.
- 5 Scroll to the **Measurement** field at the bottom of the display and set to **Timing** (if not already selected).
- 6 You should now see a display of relative timing, as shown in figure 13.
- 7 If you need to re-scale the vertical resolution, select **Controls:Marker** and then scroll to the **Time/div** field and select from settings of 1 to 50 ns.
- 8 To return to the main menu press SHIFT, then k1, then ENTER.

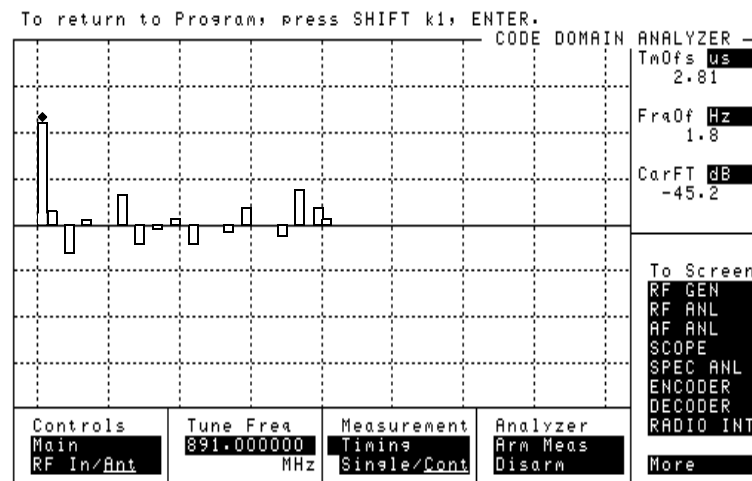

Figure 13

Notes

The **Tune Freq** displayed at the bottom of the **CODE DOMAIN ANALYZER** Screen does not indicate the true tuned frequency of the system. The tuned frequency is calculated from your entry for **Base Station Channel** and can be viewed at the bottom of the main menu screen. Do not make changes to the **Tune Freq** setting of the **CODE DOMAIN ANALYZER** screen.

If you are planning to test Code Domain Power or Code Domain Phase, you can use the **Measurement** field to activate them without having to return to the main menu.

Refer to the *HP 83203B, 83205A Cellular Adapter User's Guides* for more details on the use of the Code Domain Timing screen.

Code Domain Phase

Overview

Similar to the Code Domain Power measurement, this measurement shows the relative phase relationship of the various Walsh channels referenced to the pilot channel (Walsh 0).

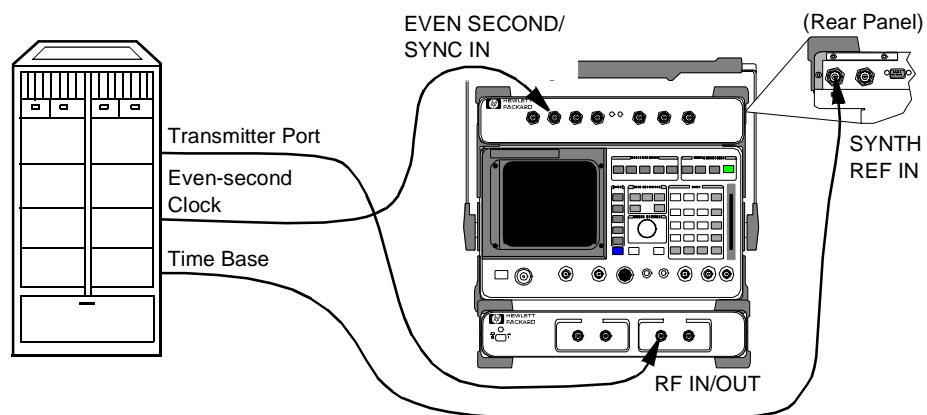

Figure 14

CAUTION:

Before performing any transmitter measurements, make sure that the power level applied to the RF IN/OUT port of the PCS Interface does not exceed the published limit. For CDMA base station signals this is 1 Watt (+30 dBm). You may have to use an external attenuator or directional coupler, depending on the power output for your transmitter. Signal levels greater than the specified maximum can cause damage to the test equipment.

Requirements

- You must have a means of turning on the base station transmitter and bringing up various Walsh channels (such as Pilot, Sync, Traffic, and Paging).
- Synchronization is required, so you must have an Even-Second clock signal and a reference timebase (typically 19.6608 MHz) from the base station.
- You must know the following about the base station and setup:
 - The base station channel number setting.
 - The PN Offset for the base-station-under-test.
 - The approximate power output at the port the test equipment will be connected to.

Steps

- 1 Connect the equipment as shown in figure 14.
- 2 In the main menu, enter the **Base Station Channel** number for the transmitter being tested.
- 3 Also in the main menu, enter the **Base Station PN Offset** for the base-station-under-test.
- 4 Scroll to and select **Go to Code Domain Analyzer Screen**.
- 5 Scroll to the **Measurement** field at the bottom of the display and set to **Phase** (if not already selected).
- 6 You should now see a display of relative phase, as shown in figure 15.
- 7 If you need to re-scale the vertical resolution, select **Controls:Marker** and then scroll to the **Phase/div** field and select from settings of 1 to 50 mRad (milliradians).
- 8 To return to the main menu press SHIFT, then k1, then ENTER.

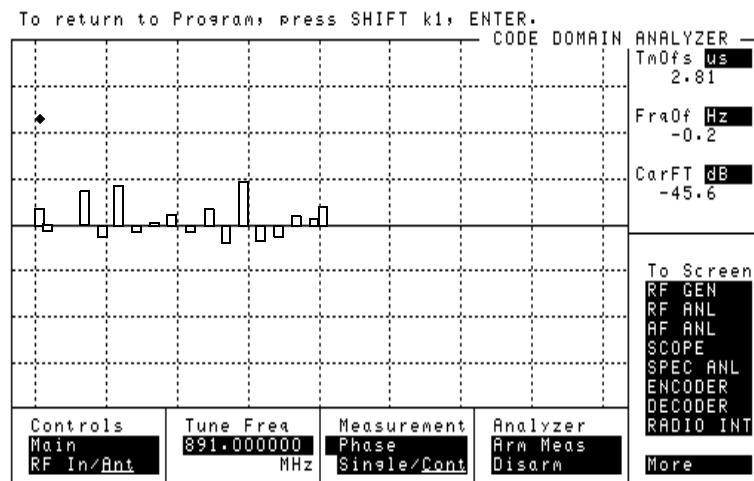

Figure 15

Notes

The **Tune Freq** displayed at the bottom of the **CODE DOMAIN ANALYZER** screen does not indicate the true tuned frequency of the system. The tuned frequency is calculated from your entry for **Base Station Channel** and can be viewed at the bottom of the main menu screen. Do not make changes to the **Tune Freq** setting of the **CODE DOMAIN ANALYZER** screen.

If you are planning to test Code Domain Power or Code Domain Timing, you can use the **Measurement** field to activate them without having to return to the main menu.

Refer to the *HP 83203B, 83205A Cellular Adapter User's Guide* for more details on the use of the Code Domain Phase screen.

Transmit Spectrum

Overview

It is often useful to look at the transmitter signal with the spectrum analyzer to see its overall symmetry and occupied bandwidth, and to identify potential sources of interference. This section details two methods for accessing the spectrum analyzer:

- Go to the spectrum analyzer with the current channel as the center frequency, see "Steps: Go to Spectrum Analyzer @ Present Chan" on page 35
- Go to the spectrum analyzer after entering a new center frequency, see "Steps: Go to Spectrum Analyzer & Enter Freq" on page 36

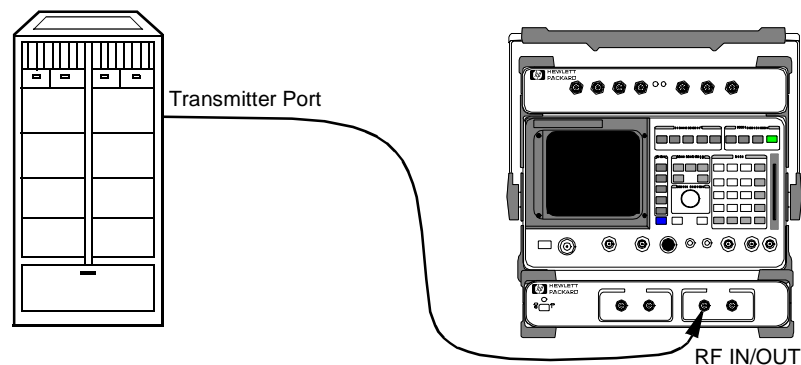

Figure 16

CAUTION:

Before performing any transmitter measurements, make sure that the power level applied to the RF IN/OUT port of the PCS Interface does not exceed the published limit. For CDMA base station signals this is 1 Watt (+30 dBm). You may have to use an external attenuator or directional coupler, depending on the power output for your transmitter. Signal levels greater than the specified maximum can cause damage to the test equipment.

Requirements

- You must have a means of turning on the base station transmitter with modulation (if looking at the transmitted signal).
- You must know the following about the base station and setup:
 - The base station channel number setting (if looking at the transmitted signal).

**Steps: Go to
 Spectrum Analyzer
 @ Present Chan**

- 1 Connect the equipment as shown in figure 16.
- 2 In the main menu, enter the **Base Station Channel** number for the transmitter being tested.
- 3 Scroll to and select **Go to Spectrum Analyzer @ Present Chan**. The spectrum analyzer display will appear and the center frequency will be set to match the channel number entered in step 2 (see figure 17).
- 4 Use the **Controls** area in the lower part of the spectrum analyzer screen to make changes to the reference level, span, and marker settings as desired.
- 5 To return to the main menu press SHIFT, then k1, then ENTER.

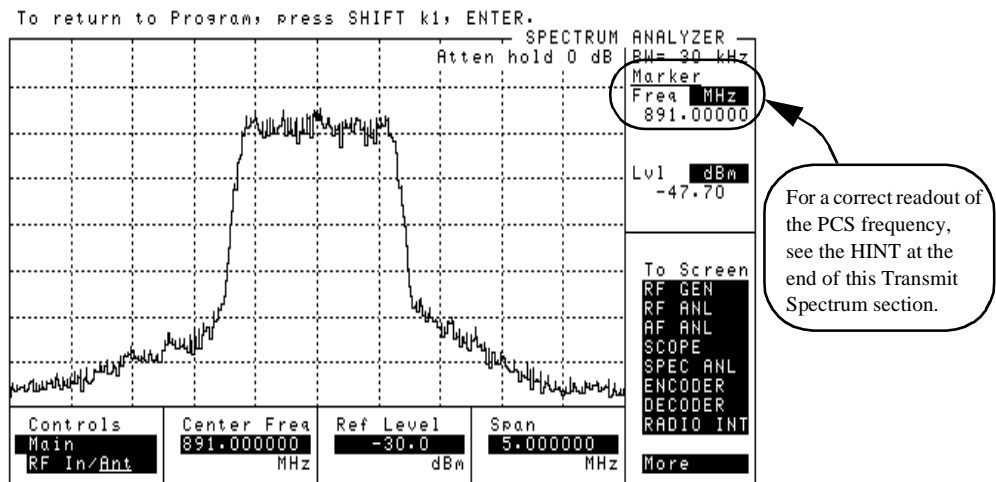
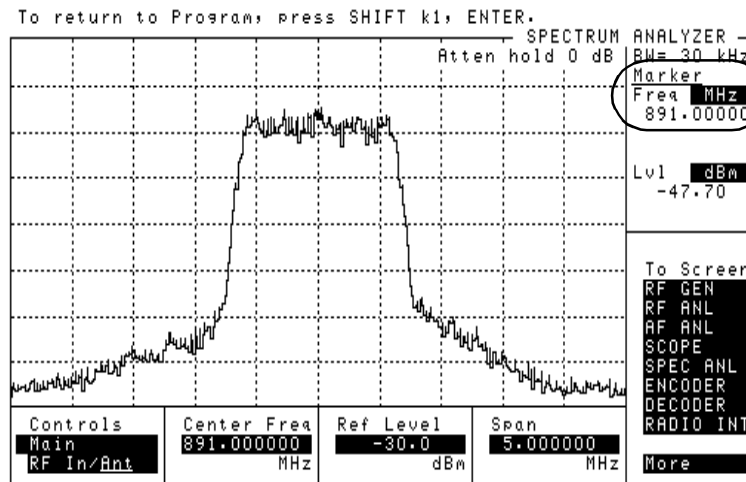

Figure 17

**Steps: Go to
Spectrum Analyzer
& Enter Freq**

- 1 Connect the equipment as shown in figure 16.
- 2 Scroll to and select **Go to Spectrum Analyzer & Enter Freq.**
- 3 Scroll to and select **Spectrum Analyzer Freq.**
- 4 Enter the frequency of interest (the range is 1850 to 1990 MHz). Press the knob or the ENTER key to see the spectrum analyzer display (see figure 18). The center frequency of the displayed signal matches the frequency you entered in this step.
- 5 Use the **Controls** area in the lower part of the spectrum analyzer screen to make changes to the reference level, span, and marker settings as desired.
- 6 To return to the main menu press SHIFT, then k1, then ENTER.



For a correct readout of the PCS frequency, see the HINT at the end of this Transmit Spectrum section.

Figure 18

Notes

For either spectrum analyzer mode (**Go To Spectrum Analyzer @ Present Chan** or **Go To Spectrum Analyzer & Enter Freq**), do not make changes to RF port selections, tune frequency, or other “setup” fields. You may change spectrum-analyzer-specific settings such as **Ref level**, **Span**, and **Marker** settings.

Note that the marker’s displayed values (upper right of spectrum analyzer screen) will not reflect the actual tuned frequency of the System:

- **Freq**: shows the marker frequency as measured at the ANT IN port of the Test Set after it has been downconverted in the PCS Interface.

HINT:

You can use the REF SET function of the Test Set to correct the marker readout for frequency. Because the PCS Interface uses a fixed LO (at 1050 MHz) for downconversion, you can compensate for the offset. Scroll the cursor to the **Freq** field, press and release the SHIFT key, then the INCR÷10 key, the minus key, 1050, and ENTER.

- **Lvl**: the displayed level is not compensated for losses through the PCS Interface. These losses change based on internal attenuator settings and the frequency. If you need accurate power level measurements, use the Average Power function.

Receiver Sensitivity

Overview

In this test, the CDMA generator sends a calibrated signal to the base station's receiver. For a given RF level, the resulting Frame Error Rate (FER) is measured. Standards specify an FER of 1.0% or less at an RF level of -119 dBm.

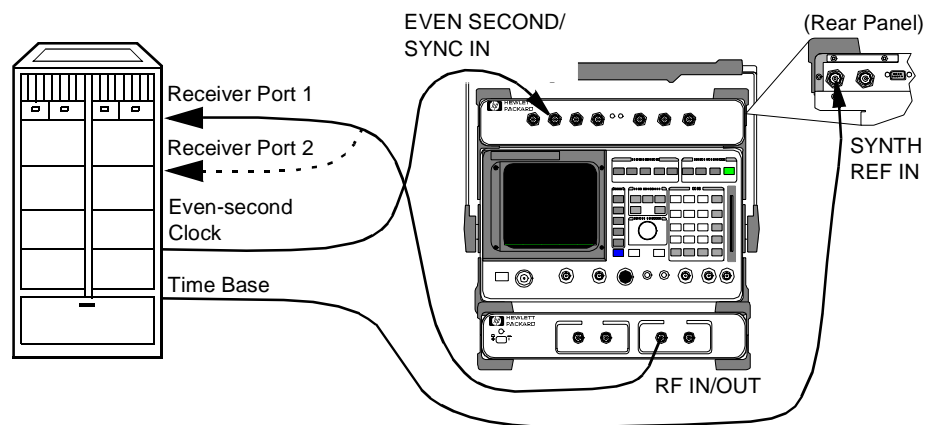

Figure 19

Requirements

- You will need a means of reading the Frame Error Rate (FER) from the base station. The CDMA generator sends a random bit pattern which the base station decodes and uses to calculate FER. Some means of reading the calculated value is required. Often this is done via a laptop PC connected to the station equipment by serial or LAN port.
- This test requires synchronization between the System's CDMA signal generator and the base-station-under-test. This is achieved using the Even-Second clock from the base station.
- The CDMA generator should be connected directly to the receiver input(s). This can be achieved by connecting to only one at a time or by using a splitter to connect to both at once (if there is more than one receiver test port).
- You must know the following about your base station and setup:
 - The base station channel number setting.
 - The PN Offset for the base-station-under-test (typically 0).
 - The path loss for cabling and any attenuation between the RF IN/OUT port of the PCS Interface and the receiver test port of the base station.

Steps

- 1 Connect the equipment as shown in figure 19.
- 2 In the main menu, enter the **Base Station Channel** number.
- 3 Scroll to and select **Setup CDMA Generator**.
- 4 Scroll to **RF Level** and enter the signal generator level for your sensitivity measurement (in dBm).
- 5 Scroll to and set the **Generator Mode** to **Data**.
- 6 Scroll to and set the **Data Source** to **Random**.
- 7 At this time, the CDMA generator is sending random data at the level you entered in step 4.
- 8 You can now read the calculated FER from the PC or other means.
- 9 If desired, use the **RF Level** selection to change the signal strength and read the resulting FER.
- 10 To return to the main menu, press the **Prev Menu** (k5) USER key.

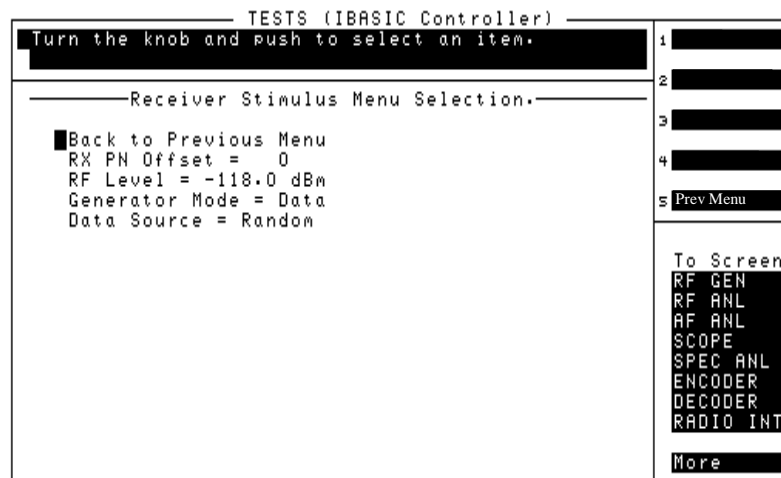

Figure 20

Notes

The cable loss (including losses through splitters, couplers, and so forth) entered into the **Configuration Information Menu** screen is taken into account when signal generator RF level settings are made. The level at the PCS Interface RF IN/OUT port is increased by the loss amount so the displayed RF level indicates the true level delivered to the base station's receiver test port.

The field **RX PN Offset** is provided for you to change the offset for your testing, if required. Normally, mobiles transmit on system time which corresponds to an offset of 0 (the default value in the software menu).

Receiver Performance in Additive Noise

Overview

In this test, the CDMA signal generator is used with the Additive White Gaussian Noise (AWGN) source, to simulate an uplink signal to the base stations' receiver. Various levels of signal-to-noise (E_b/N_o) can be used and the resulting Frame Error Rate (FER) is measured at each E_b/N_o level.

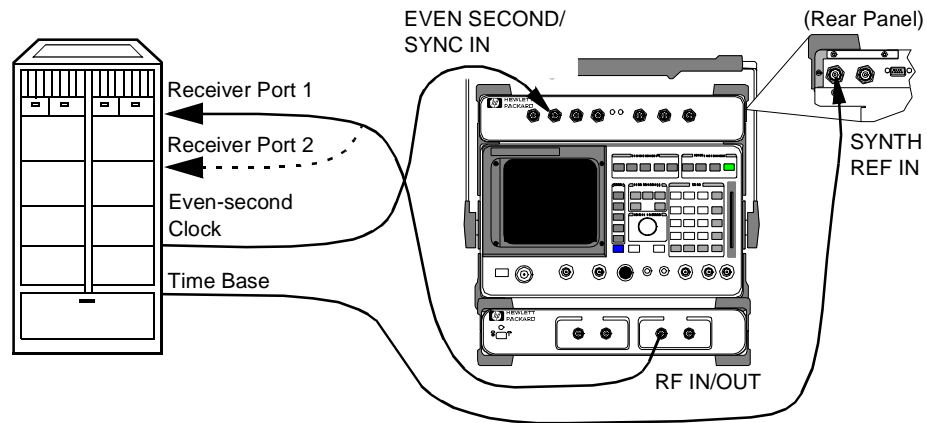

Figure 21

Requirements

- You will need a means of reading the Frame Error Rate (FER) from the base station. The CDMA generator sends a random bit pattern which the base station decodes and uses to calculate FER. Some means of reading the calculated value is required. Often this is done via a laptop PC connected to the station equipment by serial or LAN port.
- This test requires synchronization between the System's CDMA signal generator and the base-station-under-test. This is achieved using the Even-Second clock from the base station.
- The CDMA generator should be connected directly to the receiver input(s). This can be achieved by connecting to only one at a time or by using a splitter to connect to both at once (if there is more than one receiver test port).
- You must know the following about your base station and setup:
 - The base station channel number setting.
 - The PN Offset for the base-station-under-test (typically 0).
 - The path loss for cabling and any attenuation between the RF IN/OUT port of the PCS Interface and the receiver test port of the base station.

Steps

- 1 Make the equipment connections as shown in figure 21.
- 2 On the main menu screen, enter the **Base Station Channel** number.
- 3 Scroll to and select **Setup CDMA Generator**.
- 4 Set the **Generator Mode** to **Eb/No**. Note that a new field appears called **Eb/No Level**.
- 5 Set the **Eb/No Level** as called for in the test standard or in your base station test procedures (for example, 5.5 dB).
- 6 Set the **RF Level** as called for in your test procedure.
- 7 At this point, the CDMA signal generator is transmitting with random data and noise. Read the resulting Frame Error Rate from the base station.
- 8 If desired, change the **Eb/No Level** according your test procedure and read the new FER value.
- 9 When finished, return to the main menu by selecting **Back to Previous Menu** or press the **Prev Menu** (k5) USER key.

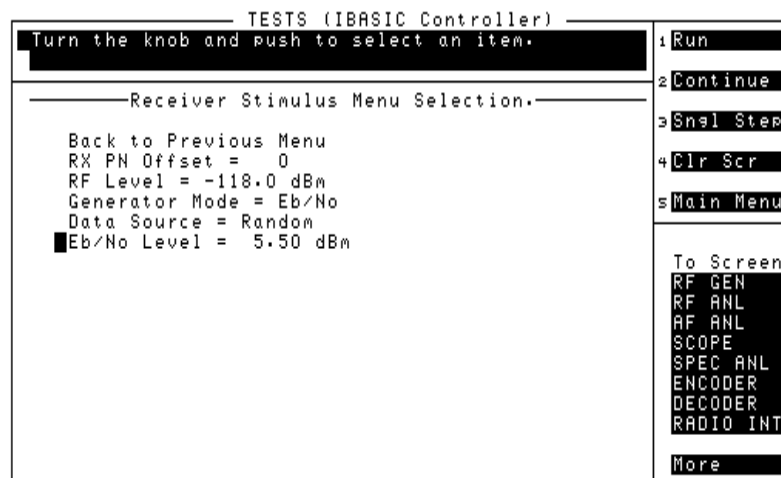

Figure 22

Notes

The cable loss (including losses through splitters, couplers, and so forth) entered into the **Configuration Information Menu** screen is taken into account when signal generator RF level settings are made. The level at the PCS Interface RF IN/OUT port is increased by the loss amount so the displayed RF level indicates the true level delivered to the base station's receiver test port.

The field **RX PN Offset** is provided for you to change the offset for your testing, if required. Normally, mobiles transmit on system time which corresponds to an offset of 0 (the default value in the software menu).

Operating Overview

This chapter describes general operation of the Software.

Overview

This chapter provides detail on Software operations not covered in chapter 1, "Getting Started" or chapter 2, "Making Measurements".

Configuration Information

- "Compensating for TX and RX Measurement Path Loss" on page 45
- "Saving Configuration Information to a Memory Card" on page 46
- "Loading Configuration Information from a Memory Card" on page 48
- "Using Autostart" on page 49
- "Viewing Instrument Connections" on page 50

Reference Information

- "An Alternative System-to-Base-Station Timebase Configuration" on page 52

Compensating for TX and RX Measurement Path Loss

The Software can compensate for losses (through cables, attenuators, couplers, and so forth) between the System and the base station for the best accuracy in average power and receiver measurements. The loss values are entered into the **Configuration Information Menu** and are saved on a memory card if the **Save Info To Card** feature is used.

Requirements

You must know the following loss values:

- The total loss (in dB) between the base station's transmitter test port and the RF IN/OUT port of the PCS Interface.
- The total loss (in dB) between the RF IN/OUT port of the PCS Interface and the base station's receiver test port.

These values should include losses through any cables, splitters, attenuators, and directional couplers used in your test setup.

Steps

- 1 From the main menu, select **Configuration Information Menu**.
- 2 Scroll to and select **TX Measurement Path Loss** and enter the loss between the transmitter test port and the RF IN/OUT port of the PCS Interface. Once selected, you can use the knob to scroll up and down in 1 dB increments or you may enter the value directly using the DATA keys. Press ENTER or the knob when the correct value appears in the inverse field.
- 3 Scroll to and select **RX Measurement Path Loss** and enter the total loss between the PCS Interface RF IN/OUT port and the receiver test port.
- 4 To return to the main menu, press the **Prev Menu** (k5) USER key.

Notes

The loss values you entered in the steps above *will not be saved* unless you use the **Save Info to Card** feature. See "Saving Configuration Information to a Memory Card" on page 46.

Saving Configuration Information to a Memory Card

The information about your setup and base station entered into the **Configuration Information Menu** can be saved to an SRAM memory card. This saves time when running the Software at a later date and helps to prevent entry errors. The stored data is loaded automatically any time you re-run the Software. If you make changes to the on-screen values and you want to return to your defaults, you can also load the stored data manually.

Requirements

- SRAM card with battery, initialized (see Notes), with a minimum of 4 KB of free space.

Steps

- 1 Check to make sure that the following entries in the **Configuration Information Menu** are set with your desired values:
 - Base Station Channel**
 - Base Station PN Offset**
 - Base Station Reference Freq**
 - Base Station Reference To**
 - Base Station Power Out**
 - TX Measurement Path Loss**
 - RX Measurement Path Loss**
 - Beep**
- 2 Remove any memory cards presently in the front-panel slot and insert your SRAM card.
- 3 From the main menu, choose the **Configuration Information Menu**.
- 4 Scroll down to **Save Info To Card** and press the knob. The screen will be updated and the storage will be complete.

Notes

See "Loading Configuration Information from a Memory Card" on page 48 for a description of how your saved values can be reloaded.

If you need to initialize a memory card, follow these steps:

- 1 Be sure that you do not have any data stored on the card. *Initialization deletes all programs stored on a card.* If files exist on the card, then it has already been initialized.
- 2 Check to see that the write-protect switch on the edge of the card is *not* in the "Safe" position.
- 3 Insert the card into the front-panel slot on the Test Set.
- 4 From the Software main menu, select **Go To Spectrum Analyzer @ Present Chan** to pause the program.
- 5 Press the TESTS key.
- 6 Scroll to and select **Proc:Save/Delete Procedure**.
- 7 Press **Init Card** (k3).
- 8 You will be asked to verify the initialization; press the YES key (ON/OFF).
- 9 Wait for the asterisk in the upper right of the display to return to a "dash".
- 10 To return to Software control press SHIFT, then k1, then ENTER.

Loading Configuration Information from a Memory Card

The information about your setup and base station entered into the **Configuration Information Menu** can be saved to an SRAM memory card. This data is loaded automatically when you re-run the Software (if the card is present in the front-panel slot at runtime). You can also load the data manually. This procedure gives steps for manually loading the data.

Requirements

- SRAM card with the Configuration Information entries saved on it.

Steps

- 1 Remove any cards presently in the front-panel slot and insert the SRAM card containing the previously-stored data.
- 2 From the main menu, choose the **Configuration Information Menu**.
- 3 Scroll down to **Load Info From Card** and press the knob. The loading process takes only a fraction of a second. You should see your saved values in the **Configuration Information Menu**.

Notes

Configuration information saved to a card is loaded into the **Configuration Information Menu** in the following cases:

- When the Software is first run and the SRAM card with the previously-saved information is in the slot on the Test Set's front panel before the **Run Test** (k1) key is pressed.
- When you load the data manually, using the steps above.

See "Saving Configuration Information to a Memory Card" on page 46 for a description of saving the settings to the card.

Using Autostart

“Autostart” is a feature of the Test Set’s IBASIC controller and is used to customize the instrument for a specific task. The autostart feature allows you to “flip a switch” to configure the Test Set to automatically run whatever program is currently stored in its non-volatile memory when it is first turned on.

Turning On the Autostart Feature

If you would like your System to “boot up” into the main menu of the CDMA/PCS BS Test Software screen, follow these steps:

- 1 Scroll and select **Go to Spectrum Analyzer @ Present Chan**. This is done only to pause the Software in a known state.
- 2 Press the TESTS key.
- 3 Scroll to and select **Execution Cond**.
- 4 Scroll to the last field at the bottom of the screen and toggle **Autostart Test Procedure on Power-up** to **On**.
- 5 To return to the Software main menu press SHIFT, then k1, then ENTER.

With this setting, whenever you apply power to the Test Set it will automatically run the Software program loaded in non-volatile memory. This will configure the Test Set to act as a “CDMA tester” (assuming that the CDMA/PCS Software is loaded) and saves steps in testing.

If you power up the Test Set later and want to use other manual functions, simply select **Quit** (k5) from the main menu and then select the other function.

Turning Off the Autostart Feature

Turning off this mode uses the same steps above, except you would toggle the **Autostart Test Procedure on Power-up** mode to **Off**.

Notes

The autostart feature continues to work even if you load and run another program on the Test Set. The new program will be automatically run the next time you turn on the Test Set.

Viewing Instrument Connections

In setting up your System, you may have questions about connections between the Test Set, Cellular Adapter, and PCS Interface as well as the connections to the CDMA/PCS base station. In the **Configuration Information Menu** are two selections that recall and display connection diagrams for the front and rear panel.

Steps

- 1 Make sure that you have your desired entries in the fields of the **Configuration Information Menu** (see Notes, below).
- 2 From the main menu, select **Configuration Information Menu**.
- 3 For a diagram of front panel connections, scroll to and select **Show Instrument Front Panel Connections**.
- 4 For rear panel connections, scroll to and select **Show Instrument Rear Panel Connections**.
- 5 You can exit the connection diagram screen by pressing the **Continue** (k2) USER key.
- 6 Press **Prev Menu** (k5) to return to the main menu level.

Notes

The connection diagrams change as a function of the entries into the **Configuration Information Menu**. For this reason, make sure you have entered your desired values *before* viewing the instrument connections.

Connection diagrams are also shown in chapter 2, "Making Measurements" for each CDMA test.

Setting the System “Beep”

The Software can provide an audio tone to let you know when selections are made in the menu screens. This “beep” sounds when you change menu screens, choose an entry field, and when you complete an entry.

You can customize the “beep” function as follows:

- If you don’t want to hear the “beep” at all, you can turn it off.
- In its default mode, the “beep” function is set to a medium volume (Quiet).
- For noisy environments, you can set the “beep” to a high volume (Loud).

Steps

- 1 From the main menu, select **Configuration Information Menu**.
- 2 Scroll to and select **Beep**.
- 3 Use the cursor to scroll and choose one of the three options (**Off**, **Quiet**, or **Loud**).
- 4 Press **Prev Menu** (k5) to return to the main menu level.

Notes

The “beep” level you set *will not be saved* unless you use the **Save Info to Card** feature. See "Saving Configuration Information to a Memory Card" on page 46.

An Alternative System-to-Base-Station Timebase Configuration

Chapter 1 describes the most common method of connecting timebases between the System and the base-station-under-test. This section shows an alternative way of connecting the timebases using the CDMA TIMEBASE IN port of the CDMA Cellular Adapter (rather than the rear-panel SYNTH REF IN port).

Steps

- 1 Connect the timebases as shown in figure 23. Note the connections from the BNC “tee” on the Test Set’s 10 MHz REF OUTPUT to both the Cellular Adapter *and* PCS Interface.
- 2 From the main menu, select **Configuration Information Menu**.
- 3 Note the selection for the **Base Station Reference To** field. If it is set to **SYNTH REF IN**, scroll down to the line and press the knob to change it to read **CDMA TB IN**. Otherwise, you may skip this step.
- 4 Note the selection for **Base Station Reference Freq**. If it does not match the timebase frequency supplied by the base station (typically 19.6608 MHz or 10 MHz), scroll to the line, press the knob, and select the appropriate value.
- 5 To return to the main menu, press the **Prev Menu** (k5) USER key.

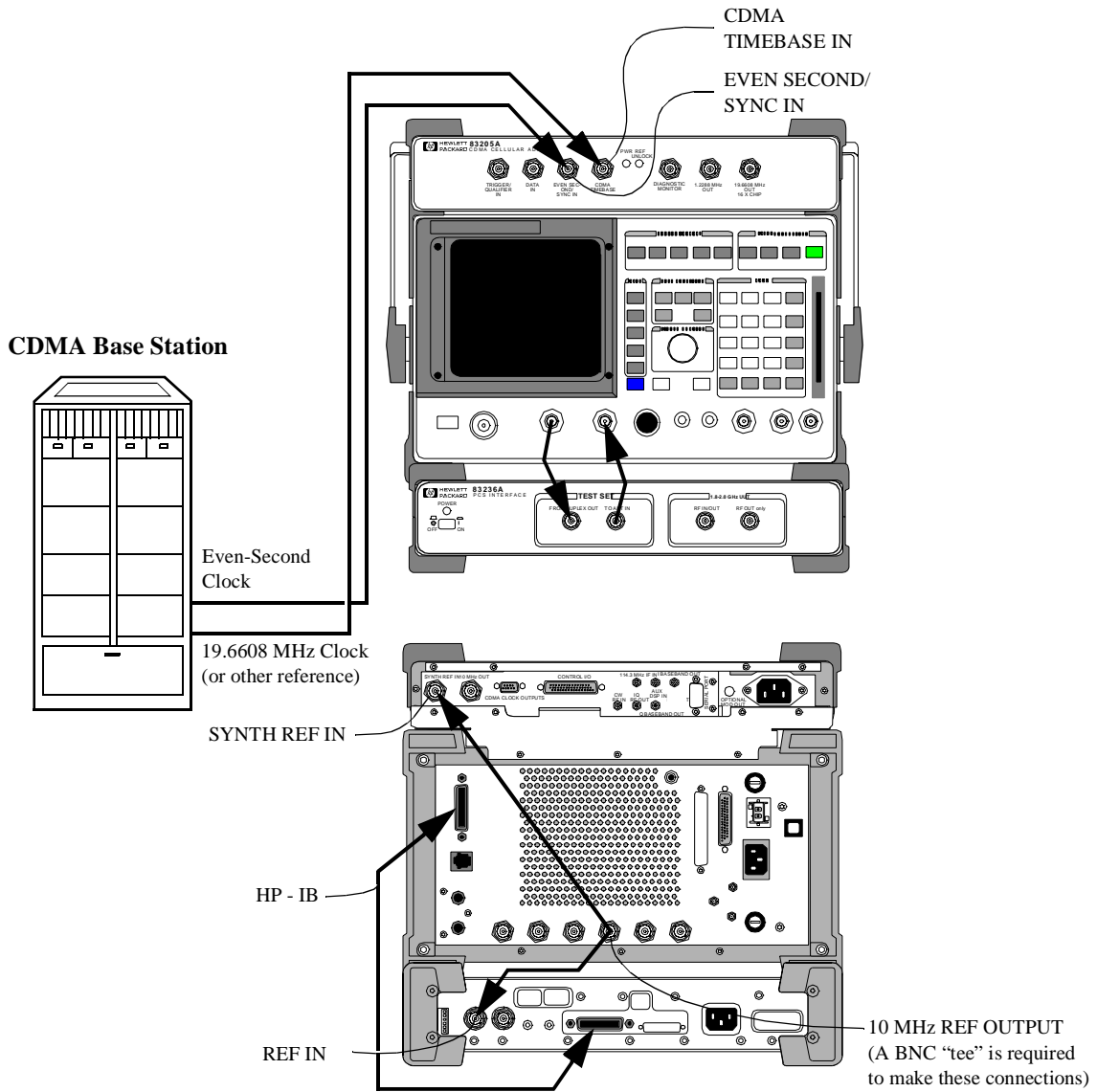

Figure 23

Notes

The timebase settings you made in the steps above *will not be saved* unless you use the **save Info to Card** feature. See "Saving Configuration Information to a Memory Card" on page 46.

Troubleshooting

Use this chapter if you have encountered Software or measurement errors or if you are questioning measurement results.

Overview

Use table 1 to locate your problem or a received error message, then refer to the page number shown.

	Problem or error message	Refer to:
Loading and running the software	Memory overflow errors	"Memory Overflow Errors" on page 57
	Message: HP-IB Command not accepted. Option not installed.	"System Configuration Errors at Runtime" on page 58
	Message: Verify PCS Interface is connected and on. Retry?	
	Message: Compensation not performed. Check DUPLEX OUT cable. Retry?	"Other System Configuration Errors" on page 59
	Configuration Information is not updated	"Configuration Information is Not Updated as Saved" on page 59
	The menu screens you see do not match those in this book	"Menu Screens in this Book do not Match the Screens that You See" on page 60
Measurements	Message: Cannot Correlate to input signal. Check setup.	"CDMA Measurement not Correlating" on page 61
	Unable to read frame error rate (FER) or unexpectedly high readings (receiver tests)	"Frame Error Rate (Receiver Measurements)" on page 62
Suspect Measurement Results	Average power	"Average Power" on page 64
	Modulation quality (rho)	"Rho Measurements" on page 65
	Code domain power, timing, or phase	"Code Domain Measurements" on page 65
	Receiver tests	"Receiver Tests" on page 66

Table 1

Errors When Loading and Running the Software

Memory Overflow Errors

Problem:

The random access memory (RAM) space of the Test Set is shared by IBASIC programs and the Save/Recall storage registers. If you have saved a large number of registers in your Test Set, you may encounter a “memory overflow” error when you first attempt to load the Software.

Solution:

You will need to clear up some RAM space by deleting some or all of your saved registers. You can do this selectively (one register at a time) or you can clear all storage registers at once (globally).

ATTENTION:

Clearing the registers, whether selectively or globally, is permanent. You cannot retrieve the registers once deleted. You have an option to save registers to a RAM memory card, as well. Consult the *HP 8921 User's Guide* for instructions on this procedure.

To Clear a Single Register at a Time:

- 1 Press the RECALL key.
- 2 Scroll the cursor to the register to be deleted.
- 3 Press the ON/OFF key.
- 4 Press the YES key (same key) to confirm.
- 5 The register is cleared.

To Clear All Save Registers:

- 1 Press the RECALL key.
- 2 Scroll down to ***Clr All*** and press the knob.
- 3 Press the YES key to confirm.
- 4 All Save registers are now cleared.

**System
Configuration
Errors at Runtime**

Problem:

When it is first run, the Software checks to see that all required elements of a CDMA/PCS test system are present. If it does not find a CDMA Cellular Adapter or a PCS Interface, it will report the following errors:

HP-IB Command not accepted. Option not installed.:

This error will be reported if the Software cannot “find” the CDMA Cellular Adapter as an installed option on the Test Set.

- 1 Make sure that you are using either the HP 83203B or HP 83205A CDMA Cellular Adapter in your System.
- 2 Verify that you have supplied the Cellular Adapter with AC power. The front-panel PWR light should be illuminated.
- 3 If the unit is powered on and you still get this message, you will need to check the rear-panel connections between the Test Set and Cellular Adapter, especially the CONTROL I/O cable between the two units. Refer to the Installation chapter of the Cellular Adapter’s manual for connections.

Verify PCS Interface is connected and on. Retry?:

This error will be reported if the Software cannot “find” the HP 83236A PCS Interface on the HP-IB bus.

- 1 Verify that you have supplied the PCS Interface with AC power and that the POWER switch is on. The front-panel POWER light should be illuminated.
- 2 If the unit is powered on and you still get this message, check the rear-panel HP-IB connection between the Test Set and Cellular Adapter.
- 3 Confirm that the rear-panel HP-IB Address Selector switch is set to “HP-IB” (*not* “Ser”). If the switch is in the wrong position, correct it and cycle power on the PCS Interface.

Other System Configuration Errors

Problem:

Additional errors can be reported when using the Software, depending on which measurement modes are being used:

Compensation not performed. Check DUPLEX OUT cable. Retry?

This error can be reported if the cabling between the Test Set and PCS Interface is not correct.

- 1 Make sure there is a cable connecting the FROM DUPLEX PORT of the PCS Interface to the DUPLEX OUT port of the Test Set.
- 2 If the error persists, try replacing the cable with a new one.

Configuration Information is Not Updated as Saved

Problem:

If you have used the **Save Info to Card** feature of the **Configuration Information Menu**, your configuration should be loaded when the Software is first run. You can also load it at any later time in the **Configuration Information Menu**. If you notice that the Configuration Information is not being updated, it is most likely because the file is not being found.

Solution:

Make sure that the RAM card with the previously-saved Configuration Information is in the slot on the Test Set's front panel. If the card is present in the slot and you still cannot load the information, you should repeat the procedure "Saving Configuration Information to a Memory Card" on page 46.

**Menu Screens in
this Book do not
Match the Screens
that You See**

Problem:

You may have loaded another software procedure from the memory card that is shipped with each PCS Interface. Procedures for System Connectivity (SYS_CONN) and Manual Control (MANUAL) also reside on the memory card and are loaded in the same manner as the CDMA/PCS BS test software.

Solution:

- 1 Return to the main menu. If it does not read **CDMA PCS Main Menu** at the top of the display, you most likely have another program loaded and running.
- 2 Pause the program by pressing the CANCEL key and press the TESTS key. In the TESTS menu, the **Procedure Filename** should be **PCSCDMA**.
- 3 If not, follow the steps in "Getting Started" in chapter 1 to load and run the CDMA/PCS BS test software.

Errors While Attempting Measurements

CDMA Measurement not Correlating

Problem:

If your System is not set up correctly for many of the tests, you may see the following message posted at the top of the display:

Cannot Correlate to input signal. Check setup.

The error can occur while in many of the menus, but it will affect measurement results in the following screens:

- **CODE DOMAIN ANALYZER**
- **CDMA ANALYZER**

Possible causes and remedies:

1 **Base Station Channel** entry.

The Software tunes the System to the transmitter frequency based on your entry for **Base Station Channel**. The entry must match the channel your base station is set to transmit on. Verify the channel number entry in the **Base Station Channel** field on the main menu screen. If you want to verify the *frequency* the System is tuned to, see the **TX Freq** setting at the bottom of the main menu screen.

2 **PN Offset** entry.

For proper correlation, you must enter the **PN Offset** value that matches that of the transmitter being tested. Check the entry in the main menu level.

3 Missing an Even-Second clock timing signal.

You must have access to the Even-Second clock signal from the base station to achieve proper correlation to the CDMA signal. Verify that the signal is accessible and make sure that it is connected to the **EVEN SECOND/SYNC IN** port on front of the Cellular Adapter.

4 System timebase reference not connected.

Verify that you have access to the base station's reference timebase signal (typically 19.6608 MHz). The reference should be connected to the **SYNTH REF IN** port on the rear of the Cellular Adapter. If configured correctly, the **REF UNLOCK** indicator on the Cellular Adapter should *not* be on.

5 Transmitter not turned on.

You must have a means of controlling the cell site equipment, including the ability to turn on a given transmitter. If your tool (typically a PC) shows the information, verify that the transmitter is turned on and that it matches the channel entry in step 1.

- 6 The Software sets up default entries for **Trig Event** and **Qual Event** (used in the **CDMA ANALYZER** screen). If these fields have been changed or the default settings do not work for your system, you may need to update the entries. Refer to “Solving Triggering Problems” in the Troubleshooting chapter of the *HP 83203B, 83205A User’s Guides*.

Frame Error Rate (Receiver Measurements)

Problem:

If your System is not set up correctly for receiver tests, you may see the results (extremely high FER or inability to return a measurement) on the tool you use for displaying the Frame Error Rate calculated by the base station.

The error can occur while using the following menu screen:

- **Receiver Stimulus Menu** (CDMA Generator)

Possible causes:

- 1 Missing an Even-Second clock timing signal.

You must have access to the Even-Second clock signal from the base station to achieve proper correlation to the CDMA signal. Verify that the signal is accessible and make sure that it is connected to the EVEN SECOND/SYNC IN port on front of the Cellular Adapter.
- 2 System timebase reference not connected.

Verify that you have access to the base station’s reference timebase signal (typically 19.6608 MHz). The reference should be connected to the SYNTH REF IN port on the rear of the Cellular Adapter. If configured correctly, the REF UNLOCK indicator on the Cellular Adapter should *not* be on.
- 3 Missing or faulty connections from the PCS Interface output to the receiver inputs of the base station.

Check to see that the RF IN/OUT port of the PCS Interface is connected to the receiver test port of the base station being tested.
- 4 Incorrect **Base Station Channel** entry.

The Software tunes the CDMA Generator to a receive frequency based on your entry for **Base Station Channel**. The entry must match the channel your base station is set to receive on. Verify the channel number entry in the **Base Station Channel** field on the main menu screen. If you want to verify the *frequency* the Generator is set to, see the **RX Freq** setting at the bottom of the main menu screen.

5 RX PN Offset not set to zero.

For receiver testing, the CDMA Generator is simulating the reverse channel (uplink) signal as it would be sent by a mobile phone. Mobiles transmit on system time, so the PN Offset should be set to zero. Make sure that the field **RX PN Offset** has an entry of 0.

6 CDMA Generator level delivered to the receiver test port of the base station is low.

Verify that the entry for **RF Level** in the **Receiver Stimulus Menu Selection** matches the level intended for receiver (FER) tests. Also, you should check your entry for **RX Measurement Path Loss** in the **Configuration Information Menu**. If, in reality, you have much more loss than is indicated in the entry, the RF level at the receiver test port will be much less than is indicated in the CDMA Generator menu screen.

7 Incorrect setting for CDMA Generator Mode and/or **Data Source**.

In the **Receiver Stimulus Menu Selection** screen, the **Generator Mode** should be set to **Data** and the **Data Source** should be **Random**.

Suspect Measurement Results

Overview

Refer to the topics in this section if you are seeing measurement results with no indicated errors, but you are failing a test or you do not believe you're getting the right answer. The following pages list some common sources of measurement errors for each type of test.

Average Power

Potential causes of measurement error in average power readings include:

Cable loss values are incorrect

Since the Software will compensate for the cable loss between your base station's transmitter test port and the System, it is very important that you have the correct values entered into the **Configuration Information Menu**.

You can view the loss value in the Average power menu. If they do not match your setup (do not forget to allow for losses through couplers, attenuators, and so forth) go to the **Configuration Information Menu** and enter the correct value under **TX Measurement Path Loss**.

Power meter not zeroed recently

Periodically, you should zero the power meter. This is done by pressing the **Zero Pow (k1)** key while in the **Average power** menu.

Measurement units are incorrect

Verify that the measurement display is reporting in the units that you expect for this test (choices are Watts, milliwatts, and dBm). The displayed units can be changed in the **Average power** menu using USER keys k2, k3, and k4.

Input signal is outside the measurement range of the PCS Interface

The specified range for average power measurements with the PCS Interface is -13 to +30 dBm (50 μ W to 1 W) when testing CDMA base station transmitters. Verify that the signal applied to the RF IN/OUT port of the PCS Interface falls within this range before continuing with your tests. You can use the **Go To Spectrum Analyzer** modes to view the transmitted signal.

Connections are missing or faulty

Make sure that you have connected your transmitter signal to the RF IN/OUT port on the front panel of the PCS Interface.

Rho Measurements Sources of errors in rho measurement include the following:

Input signal is outside the measurement range of the PCS Interface

The specified range for rho measurements with the PCS Interface is –13 to +30 dBm (50 μ W to 1 W) when testing base station transmitters. Verify that the signal applied to the RF IN/OUT port of the PCS Interface falls within this range before continuing with your tests.

Channels other than the Pilot are on.

For modulation quality measurements on a CDMA signal, you must have only the pilot channel active. If other channels (sync, paging, or traffic) are on you will get poor rho readings, if you get readings at all. Turn off any other code channels, if they are on before trying to re-measure rho.

Other sources of interference exist in the channel.

If other interference sources are present within the CDMA channel, you will see degraded rho performance. The spectrum analyzer modes may be used to search for other interference.

Code Domain Measurements

Sources of errors in Code Domain measurements include the following:

Channels other than the Pilot are not turned up.

Unlike the rho measurements example, code domain measurements require other code channels to be turned on. In most cases, in addition to the Pilot channel, you will have a sync channel, a paging channel, and one or more traffic channels enabled.

Receiver Tests

Sources of errors in receiver tests include the following:

Cable loss values are incorrect

Since the Software will compensate for cable loss between the System and your base station's receiver test port, it is very important that you have the correct values entered into the **Configuration Information Menu**.

You can view the loss values in the **Configuration Information Menu**. If they do not match your setup (do not forget to allow for losses through couplers, attenuators, and so forth) go to **RX Measurement Path Loss** and enter the correct value.

Sensitivity tests: random data not selected for signal source

For receiver sensitivity measurements, check to see that the CDMA Generator is set to send random data. In the **Receiver Stimulus Menu Selection** screen, the **Generator Mode** should be set to **Data** and the **Data Source** should say **Random**.

Performance in additive noise: signal source not set for Eb/No

For this test, noise is added to the channel using the AWGN generator. Verify that the **Generator Mode** is set to **Eb/No** and that the **Eb/No Level** is set to an appropriate level.

Glossary

Access Channel A reverse CDMA channel used by mobile stations for communicating to the base station. The access channel is used for short signaling message exchanges such as call originations, responses to pages, and registrations. The access channel is a slotted random access channel.

Added White Gaussian Noise (AWGN) A broadband noise source used in conjunction with a CDMA signal source to test receiver performance.

Autostart A feature of the Test Set's IBASIC controller that automatically runs any program in non-volatile memory when the power switch is set to ON.

Average Power A method of measuring the signal level of a CDMA transmitter. The sampled signal is quantified in terms of average level. Multiple samples are then time-averaged to display a final power measurement.

Base Station (BS) A fixed-location transceiver in a communications network. The land station in a cellular or PCS network carrying on a radio communication with mobile units.

CDMA See Code Division Multiple Access.

CDMA Channel The set of channels transmitted from the base station and the mobile stations on a given frequency. See also forward CDMA channel and reverse CDMA channel.

CDMA Frequency Assignment A 1.23 MHz segment of spectrum centered on

one of the 30 kHz channels of the existing analog system.

CDMA Generator A functional block in the CDMA Cellular Adapter that generates pilot PN sequences with externally or internally applied channel data. A noise generator is also incorporated that is capable of generating calibrated E_b/N_o signals.

Cellular Adapter The HP 83203B or 83205A CDMA digital cellular "top box" for the HP 8921A Cell Site Test Set.

Channel A transmission path between two points. It is usually the smallest subdivision of a particular transmission system by means of which a single type of communication service is provided.

Code Channel A subchannel of a forward CDMA channel. A forward CDMA channel contains 64 code channels. Code channel zero is assigned to the pilot channel. Code channels 1 through 7 may be assigned to either the paging channels or the traffic channels. Code channel 32 may be assigned to either a sync channel or a traffic channel. The remaining code channels may be assigned to traffic channels.

Code Division Multiple Access (CDMA) A technique for spread-spectrum, multiple-access digital communications that creates channels through the use of unique code sequences.

Glossary

Code Domain Analyzer An instrument that measures individual Walsh Channel characteristics in a CDMA channel. The Cellular Adapter can display all 64 Walsh Channels in a received signal and display their power, phase, and timing relationship.

Code Domain Phase A measurement mode that provides the relative phase relationship between various Walsh Channels and the Pilot Channel.

Code Domain Power A measurement mode that presents the signal strength of the Walsh Channels in a CDMA signal. It indicates the division of the total power in the channel as shared by the Pilot, Sync, Paging, and Traffic channels.

Code Domain Timing A measurement mode that indicates the relative timing relationship between various Walsh Channels and the Pilot Channel.

Data Block The sampled and quantized record of a portion of the IF waveform at the input to the DSP analyzer. The data block's length is determined by the **Interval** field on the CDMA ANALYZER screen.

dBm/Hz A measure of power spectral density. dBm/Hz is the power in one Hertz of bandwidth, where power is expressed in units of dBm.

dBW A measure of power expressed in terms of its ratio (in dB) to one Watt.

Downconverter An RF network using a local oscillator to translate an input signal to a lower (intermediate) frequency.

Downlink See Forward Link.

E_b The energy in an information bit.

E_b/N_0 The ratio between the energy of each information bit (E_b) and the noise spectral density (N_0). This ratio is usually expressed in dB.

Even-Second Clock A clock that occurs every two seconds.

FER See Frame Error Rate.

FIR Filter Finite Impulse Response filter. A filter for which the output, in response to an impulse input, totally dies away after a finite time interval. The term is usually used in reference to a digital filter.

Forward CDMA Channel A CDMA channel from a base station to mobile stations. The forward CDMA channel contains one or more code channels that are transmitted on a CDMA frequency assignment using a particular pilot PN offset. The code channels are associated with the pilot channel, sync channel, paging channels, and traffic channels. The forward CDMA channel always carries a pilot channel and may carry up to 1 sync channel, up to 7 paging channels, and up to 63 traffic channels, as long as the total number of channels, including the pilot channel, is no greater than 64.

Forward Link The link direction from the base station to the mobile station. Also referred to as the downlink.

Forward Traffic Channel A code channel used to transport primary traffic, secondary traffic, and signaling traffic from the base station to the mobile station.

Glossary

Frame A basic timing interval in the system. For the Access channel, paging channel, and traffic channel, a frame is 20 ms long. For the sync channel, a frame is 26.666...ms long.

Frame Clocks A phase-locked loop in the CDMA Cellular Adapter that provides the following CDMA clocks for internal or external (through the rear-panel, 9-pin connector) use:

- 2 second
- 80 millisecond
- 27 millisecond
- 20 millisecond

Frame Delay Pulse An internal timing pulse that initiates the Cellular Adapter's CDMA frame clocks. The frame delay pulse occurs after the frame delay timer expires.

Frame Delay Timer A timer that determines the interval between the sync pulse and the frame delay pulse.

Frame Error Rate (FER) A measure of the performance of a digital receiver. For a given data rate, the ratio of frames received incorrectly to the total number of frames sent. Also referred to as Frame Error Ratio.

Intermediate Frequency (IF) The frequency resulting from a downconversion process.

Mcps Megachips per second (one million chips per second).

Modulation Quality See Rho.

Modulation Symbol The output of the

data modulator before spreading. On the reverse traffic channel, 64-ary orthogonal modulation is used and six code symbols are associated with one modulation symbol. On the forward traffic channel, each code symbol (when the data rate is 9600 bps) or each repeated code symbol (when the data rate is less than 9600 bps) is one modulation symbol.

N_o Noise spectral density. See E_b/N_o .

Offset Quadrature Phase Shift Keying (OQPSK) A form of modulation that applies different data sequences to two carriers separated by 90° . The two different data sequences are staggered by half a modulation symbol time. See Also Quadrature Phase Shift Keying.

Paging Channel A code channel on the forward channel used for paging mobile stations. Of the 64 Walsh functions used for channelization on the forward link, one through seven (inclusive) can be used for paging channels.

PCS see Personal Communications Services.

PCS Interface. The HP 83236A. Used to translate signals from the PCS band into the range of the Test Set and to provide a calibrated CDMA signal source.

Glossary

Personal Communication Services (PCS) Emerging wireless networks using digital modulation formats and operating in the frequency band between 1.8 and 2.4 GHz.

Pilot Channel An unmodulated, direct-sequence, spread-spectrum signal transmitted continuously by each CDMA base station. The Pilot channel allows a mobile station to acquire the timing of the forward CDMA channel, provides a phase reference for coherent demodulation, and provides a means for signal strength comparisons between base stations for determining when to hand off.

Pilot PN Sequence A pair of modified maximal length PN sequences with period 2^{15} used to spread the forward CDMA channel and the reverse CDMA channel. Different base stations are identified by different pilot PN sequence offsets.

Pilot PN Sequence Offset Index The PN offset in units of 64 PN chips of a pilot, relative to the zero offset pilot PN sequence.

PN Chip The time duration of one binary bit in the PN sequence, which is equal to the reciprocal of the frequency at which the PN sequence generator operates. For example, if the PN generator operates at 1.2288 MHz, then a PN chip is 813.802 ns.

PN Sequence Literally "pseudo-noise sequence." A periodic binary sequence (with 0 mapped to 1, and 1 mapped to -1). Typically a PN sequence has good autocorrelation which (when normalized) equals 1 for zero shift between the two sequences, and $-1/N$, where N is the period, for all other shifts.

PN Sync Pulse A signal to the CDMA Generator that initiates pilot PN sequence generation. The start of each pilot PN sequence is synchronized at the Test Set's RF IN/OUT port to the 27 millisecond frame clock.

Quadrature Phase Shift Keying (QPSK) A form of modulation that applies different data sequences to two carriers separated by 90° .

Quadrature Spreading Frequency spreading performed using pilot PN sequences at a 1.2288 Mcps rate. Also referred to as "short sequence spreading".

Reference Signal A replica of the ideal CDMA waveform. The reference signal resides on the Cellular Adapter's DSP analyzer and is correlated with a signal-under-test to determine waveform accuracy and timing offset.

Reverse CDMA Channel The CDMA channel from the mobile station to the base station. From the base station's perspective, the reverse CDMA channel is the sum of all mobile station transmissions on a CDMA frequency assignment.

Reverse Link The link direction from the mobile station to the base station. Also referred to as the uplink.

Reverse Traffic Channel A reverse CDMA channel used to transport primary traffic, secondary traffic, and signaling traffic from a single mobile station to one or more base stations.

Glossary

Rho The measure of the waveform quality of a modulated signal in a CDMA system. A received signal is compared to an ideal, reference, signal. A high correlation between the received signal and the reference represents a high waveform quality factor.

Sync Channel A code channel in the forward CDMA channel that synchronizes the mobile station with the base station.

Sync Pulse A pulse that starts both the frame delay timer and the PN sequence delay timers. A sync pulse occurs when:

- the Test Set is powered on, or
- an external even-second clock is received on the CDMA Cellular Adapter's front-panel EVEN SECOND/ SYNC port.

System A test equipment station consisting of a Test Set, Cellular Adapter, and PCS Interface. Used for testing CDMA base station equipment operating in the PCS band.

System Time The time reference used by the network. System time is synchronous to Universal Coordinated Time (except for leap seconds) and uses the same time origin as Global Positioning Satellite (GPS) time. All base stations use the same System Time (within a small error). Mobile stations use the same System Time, offset by the propagation delay from the base station to the mobile station. See also Universal Coordinated Time.

Test Set The HP 8921A. Used for installation and maintenance of AMPS,

TDMA, and CDMA cell site equipment.

Traffic Channel A communication path between a mobile station and a base station, used primarily for communicating service-option related traffic. The term traffic channel implies a forward traffic channel and reverse traffic channel pair. See also forward traffic channel and reverse traffic channel.

Trigger Event Trigger event describes the operating state of the DSP analyzer at the time a qualified trigger causes the DSP analyzer to acquire and begin measuring the digitized IF waveform from the CDMA transmitter-under-test.

Universal Coordinated Time (UCT) An internationally agreed-upon time scale that has the same rate as atomic time. UCT is corrected by step adjustments of exactly one second as needed to remain within 0.9 seconds of astronomical time.

Uplink See Reverse Link.

Walsh Chip The shortest identifiable component of a Walsh function. There are 2^N Walsh chips in one Walsh function where N is the order of the Walsh function. On the forward CDMA channel, one Walsh chip equals $1/1.2288$ MHz, or 813.802... ns. On the reverse CDMA channel, one Walsh chip equals $4/1.2288$ MHz, or 3.255... us.

Walsh Cover A coding method that uses Walsh functions to create a set of mutually orthogonal CDMA signals. In the CDMA system, a code channel is formed by a Walsh cover.

Glossary

Walsh Function One of 2^N time-orthogonal binary functions (note that the functions are orthogonal after mapping 0 to 1, and 1 to -1).

Walsh Symbol The time necessary to transmit one Walsh function on the reverse CDMA channel.

Zero Offset Pilot PN Sequence A pilot PN sequence aligned with System Time such that the first chip on every even-second mark is the "1" following the fifteen consecutive "0"s.

A

access channel
definition, 67

Added White Gaussian Noise
definition, 67

added white gaussian noise, 40

Autostart, 49
definition, 67
turning off, 49
turning on, 49

average power, 24
definition, 67
suspect measurement results, 64

AWGN, 40
definition, 67

B

bad measurements, 64

base station
definition, 67

beep
setting volume level, 51

beginning use of the software, 11

C

cable losses
receiver path, 45
transmitter path, 45

CDMA
definition, 67

CDMA channel
definition, 67

CDMA frequency assignment
definition, 67

CDMA generator
definition, 67

CDMA measurement not correlating, 61

CDMA TIMEBASE IN port, 52

Cellular Adapter
definition, 67

channel
definition, 67

clearing Save/Recall registers, 57

code channel
definition, 67

Code Division Multiple Access
definition, 67

Code Domain Analyzer
definition, 68

code domain measurements
suspect measurement results, 65

Code Domain Phase
definition, 68

code domain phase measurement, 32

Code Domain Power
definition, 68

code domain power, 28

code domain timing, 30

compensation not performed, 59

Configuration Information
errors, 59
loading, 48
saving, 46

configure the software, 18

connect diagrams, viewing, 50

connecting timebases, 52

connections
instrument, 14

correlation, 61

correlation errors, 61

D

data block
 definition, 68
description
 product, 12

E

Eb
 definition, 68
Eb/No, 40
 definition, 68
equipment
 required, 13
errors, 55
 Configuration Information, 59
 frame error rate (FER), 62
 HP-IB, 58
 measurement, 61, 64
 measurement not correlating, 61
 memory overflow, 57
 menu screens don't match, 60
 PCS Interface, 58
 runtime, 58
 software, 57
 system configuration, 58
Even-Second clock
 definition, 68

F

FER
 definition, 68
finite impulse response filter
 definition, 68
FIR filter
 definition, 68
forward CDMA channel
 definition, 68
forward link
 definition, 68
forward traffic channel
 definition, 68
frame
 definition, 69
frame clocks
 definition, 69
frame delay pulse
 definition, 69
frame delay timer
 definition, 69
frame error rate, 40
 definition, 69
frame error rate (FER), 38, 40
frame error rate measurement problems,
 62

G

getting started, 11

H

hardware
 required, 13
HP-IB command not accepted, 58
HP-IB errors, 58

I

instrument connections, 14, 50
intermediate frequency
 definition, 69

L

Loading Configuration Information, 48
loading the software, 15

M

main menu screen, 17
making connections, 14
making measurements, 21
Mcps
 definition, 69
measurement errors, 61
measurement results
 average power, 64
 code domain measurements, 65
 receiver tests, 66
 rho, 65
measurements, 21
 average power, 24
 code domain phase, 32
 code domain power, 28
 code domain timing, 30
 modulation quality (rho), 26
 receiver performance in additive noise,
 40
 receiver sensitivity, 38
 suspect results, 64
 transmit spectrum, 34
memory overflow errors, 57
menu screen errors, 60
modulation quality
 definition, 69
modulation quality (rho), 26
modulation symbol
 definition, 69

N

navigation of software menus, 17
noise source, 40
Noise, Added White Gaussian
 definition, 67

O

offset quadrature phase shift keying
definition, [69](#)
OQPSK
definition, [69](#)

P

paging channel
definition, [69](#)
PCS Interface
definition, [69](#)
PCS Interface error messages, [58](#)
Personal Communications Services
definition, [70](#)
phase, code domain, [32](#)
pilot channel
definition, [70](#)
pilot PN sequence
definition, [70](#)
pilot sequence offset index
definition, [70](#)
PN chip
definition, [70](#)
PN sequence
definition, [70](#)
power
average, [24](#)
power, code domain, [28](#)
problems, [55](#)
product description, [12](#)

Q

QPSK
definition, [70](#)
quadrature phase shift keying
definition, [70](#)
quadrature spreading
definition, [70](#)

R

receiver performance in additive noise, 40
receiver sensitivity, 38
receiver tests
 suspect measurement results, 66
reference signal
 definition, 70
references
 connections, 52
registers
 clearing, 57
required equipment, 13
reverse CDMA channel
 definition, 70
reverse link
 definition, 70
reverse traffic channel
 definition, 70
rho, 26
 definition, 71
 suspect measurement results, 65
running the software, 15
runtime errors, 58
RX Measurement Path Loss, 45

S

Saving Configuration Information, 46
sensitivity, receiver, 38
setting up the software, 18
Show Instrument Front Panel Connections, 50
Show Instrument Rear Panel Connections, 50
software
 configuring, 18
 definition, 12
 errors, 57
 loading, 15, 57
 navigation, 17
 running, 15, 57
software definition, 12
spectrum analyzer, 34
starting to use the software, 11
suspect measurement results, 64
sync channel
 definition, 71
sync pulse
 definition, 71
System
 definition, 71
system configuration errors, 58, 59
system time
 definition, 71

T

Test Set
 definition, 71
timebase
 connections, 52
timing, code domain, 30
tone, audio, 51
traffic channel
 definition, 71
transmit spectrum, 34
trigger event
 definition, 71
troubleshooting, 55
TX Measurement Path Loss, 45

U

UCT
definition, [71](#)
Universal Coordinated Time
definition, [71](#)
uplink
definition, [71](#)

V

viewing connect diagrams, [50](#)

W

Walsh chip
definition, [71](#)
Walsh cover
definition, [71](#)
Walsh function
definition, [72](#)
Walsh symbol
definition, [72](#)

Z

zero offset pilot
definition, [72](#)